



**MANUAL DE MONTAGEM
ASSEMBLY INSTRUCTIONS
INSTRUCCIONES DE MONTAJE**

COD BR: BS 03A

COD BR: BS 03A

PEÇA	DESCRIÇÃO	QUANT.
001	LATERAL DIREITA	1
002	LATERAL ESQUERDA	1
003	TAMPO	1
004	PRATELEIRA	3
005	COSTA	1
006	PORTA	1
007	BASE	1
008	DIVISÓRIA	1

PART	DESCRIPTION	QTY
001	RIGHT SIDE	1
002	LEFT SIDE	1
003	TOP	1
004	SHELF	3
005	BACK	1
006	DOOR	1
007	BASE	1
008	PARTITION	1

PIEZA	DESCRIPCIÓN	CANTIDAD
001	LATERAL DERECHA	1
002	LATERAL IZQUIERDA	1
003	TAPA	1
004	REPISA	3
005	REVÉS	1
006	PUERTA	1
007	BASE	1
008	PARTICIÓN	1

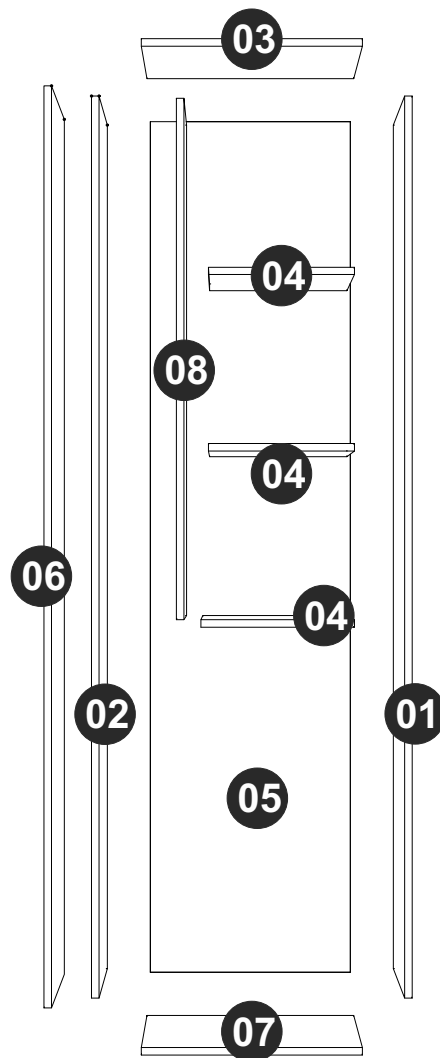



RODIZIÕES x 4
CASTERS x 4
RUEDAS x 4



EF 000248 x 19
3,5x14 CP



EF 000106 x 12
3,5x14 CC



EF 000033 x 15
8x30

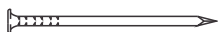

EF 000168 X 45
10x10 C/C



EF 000132 x 15
4x50 CC

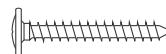

EF 000112 x 2
3,5x25 CF



GIZ x 01
CHALK x 01
TIZA x 01

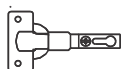

EF 000044 X 3



PUXADOR x 1
HANDLE x 1
MANIJA x 1



EF 000344 X 2



EF 000024 X 3



EF 000246 X 1
5X50 CF



EF 000016 X 1

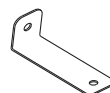

EF 000529 X 1

Utilize para medir as ferragens.

Utilice para medir el herraje.

Use for measuring the hardware.

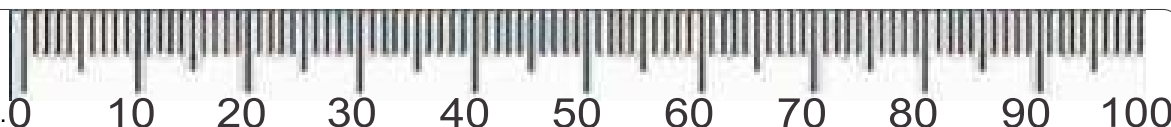

Garantia (exclusivo para o Brasil/exclusivo de Brasil/exclusive to Brazil):

A garantia dos produtos fabricados pela BRV Móveis, abrange eventuais defeitos-vícios de fabricação, no prazo estabelecido pelo código de Defesa do Consumidor, em seu artigo 26.II. o qual prevê a garantia de 90 (noventa) dias.

A = 5KG - 11LB

B = 15KG - 31.1LB

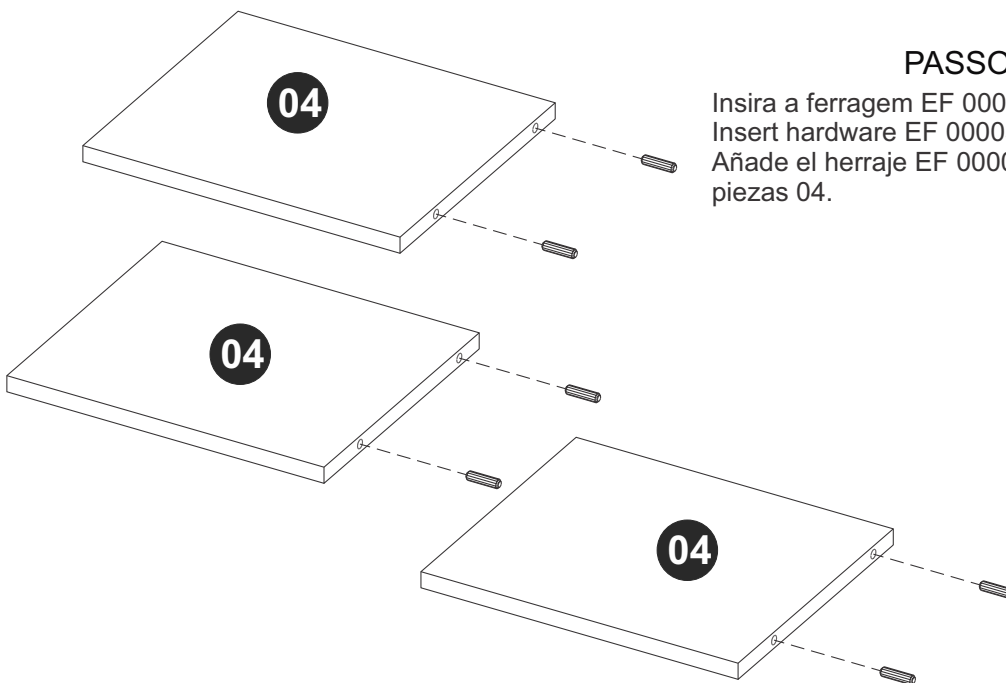
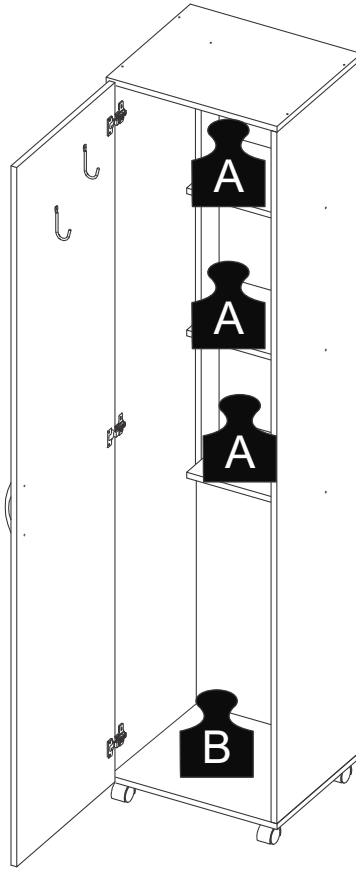

PASSO 1 / STEP 1 / PASO 1

Insira a ferragem EF 000033 nas pré-furações das peças 04.
Insert hardware EF 000033 at pre-drilled holes in pieces 04.
Añade el herraje EF 000033 en los huecos ya marcados de las piezas 04.

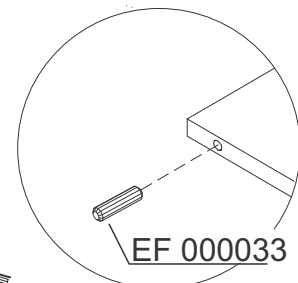

PASSO 2 / STEP 2 / PASO 2

Fixe a ferragem EF 000024 usando a ferragem EF 000106 na peça 02.
Insira a ferragem EF 000033.
Fix hardware EF 000024 using hardware EF 000106 into piece 02.
Insert hardware EF 000033.
Fije el herraje EF 000024 utilizando el herraje EF 000106 en la pieza 02.
Añade el herraje EF 000033.

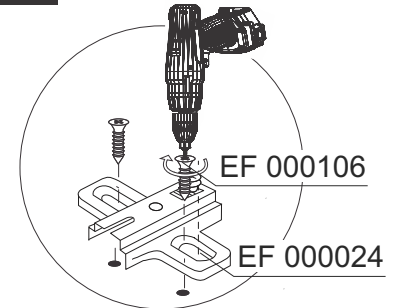
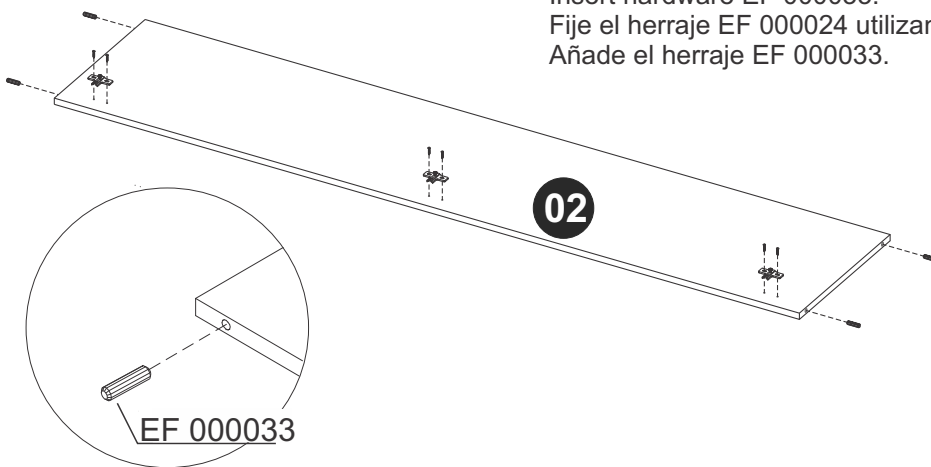

PASSO 3 / STEP 3 / PASO 3

Insira a ferragem EF 000033 nas pré-furações das peças 01 e 02.
Insert hardware EF 000033 at pre-drilled holes in pieces 01 and 02.
Añade el herraje EF 000033 en los huecos ya marcados de las piezas 01 y 02.

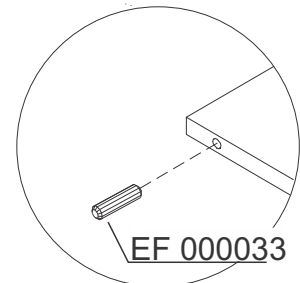
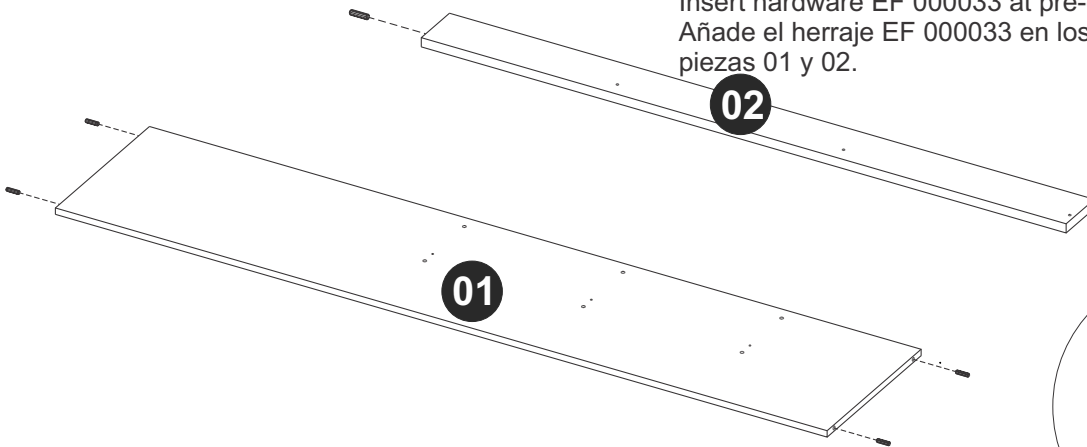

PASSO 4 / STEP 4/ PASO 4

Fixe o puxador na peça 06 usando a ferragem EF 000112.
Fixe a ferragem EF 000044 usando a ferragem EF 000106.
Fix the handle at piece 06 using hardware EF 000112. Fix hardware EF 000044 using hardware EF 000106.
Fije la manija en la pieza 06 utilizando el herraje EF 000112.
Fije el herraje EF 000044 utilizando el herraje EF 000106.

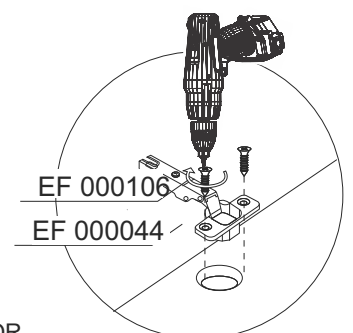
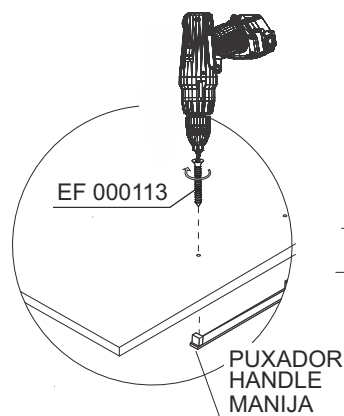
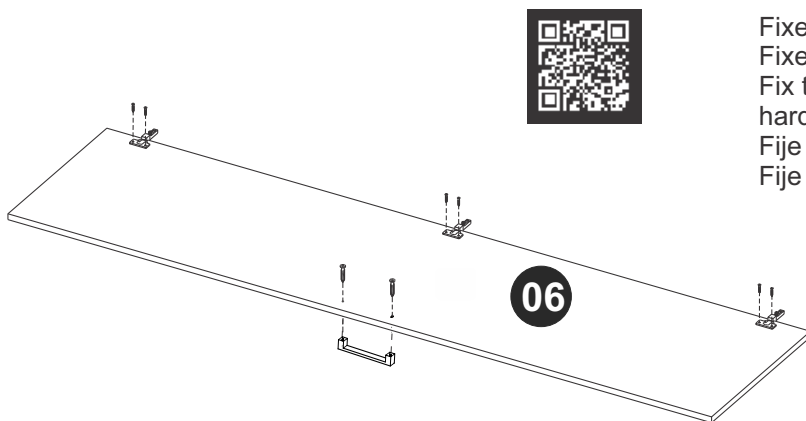

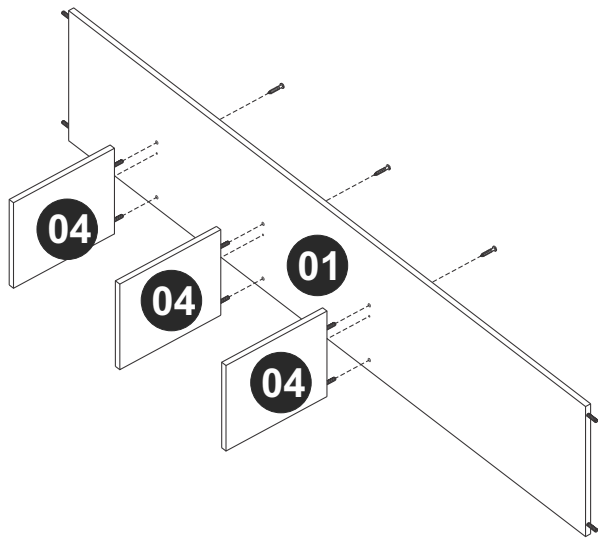

PASSO 5 / STEP 5 / PASO 5

Conecte as peças 01 e 04 utilizando a ferragem EF 000132.
 Connect pieces 01 and 04 using hardware EF 000132.
 Junte las piezas 01 y 04 utilizando el herraje EF 000132.

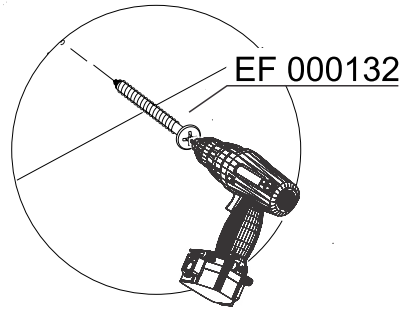

PASSO 6 / STEP 6 / PASO 6

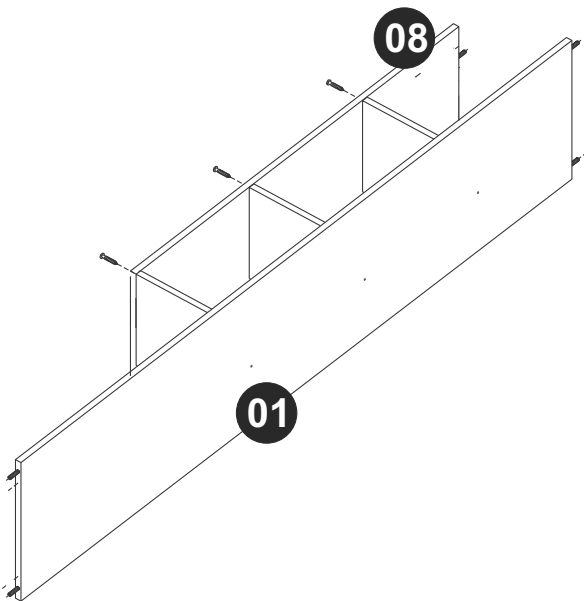

Conecte a peça 08 à parte montada no passo anterior utilizando a ferragem EF 000132.
 Connect piece 08 to the part assembled in the previous step using hardware EF 000132.
 Junte la pieza 08 a la parte armada en el paso anterior utilizando el herraje EF 000132.

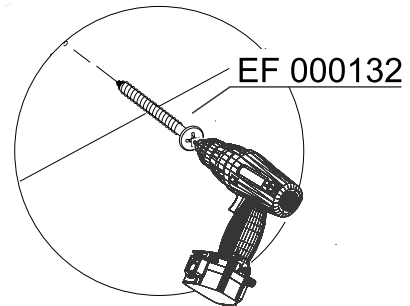

PASSO 7 / STEP 7 / PASO 7

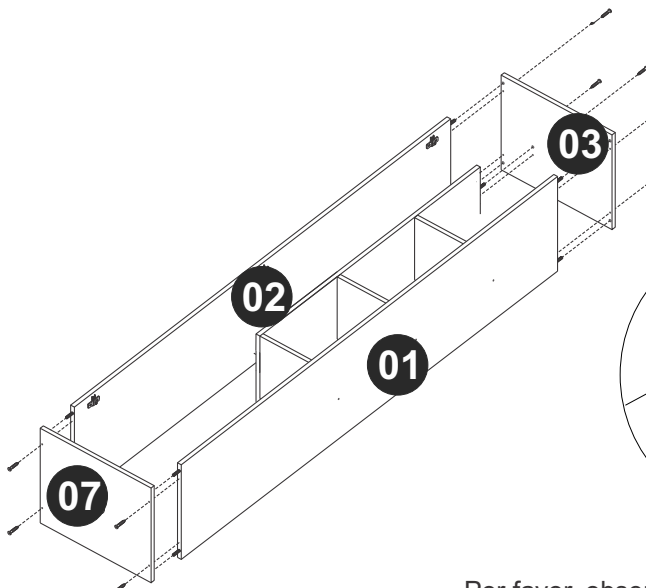

Conecte as peças 02, 03 e 07 à parte montada no passo anterior utilizando a ferragem EF 000132.
 Connect pieces 02, 03 and 07 to the part assembled in the previous step using hardware EF 000132.
 Junte las piezas 02, 03 y 07 a la parte armada en el paso anterior utilizando el herraje EF 000132.

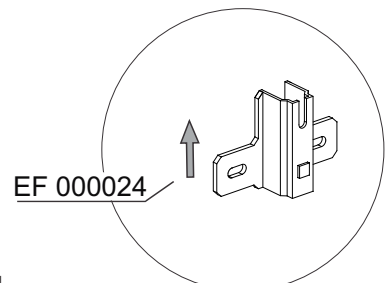
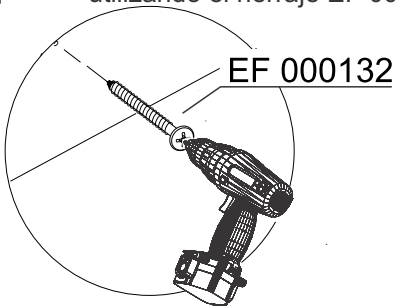

Por favor, observe a posição da ferragem EF 000024
 Please, note hardware EF 000024 position.
 Por favor, observe la posición del herraje EF000024.

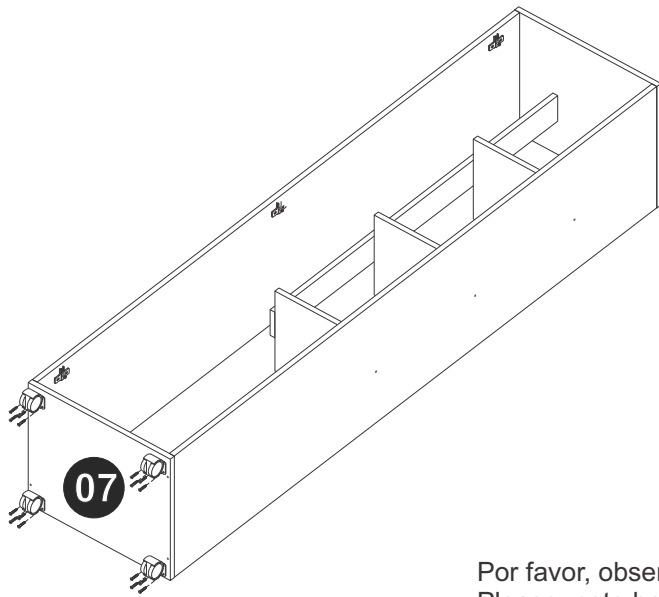

PASSO 8 / STEP 8/ PASO 8

Fixe os rodízios utilizando a ferragem EF 000106.
 Attach the casters using hardware EF 000106.
 Fije las ruedas utilizando el herraje EF 000106.

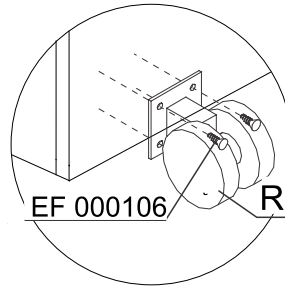

EF 000106

Rodízio/Ruedas/Caster

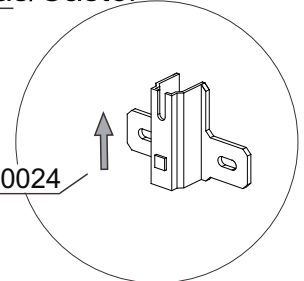

EF 000024

Por favor, observe a posição da ferragem EF 00002
 Please, note hardware EF 00002 position.
 Por favor , observe la posición del herraje EF000024

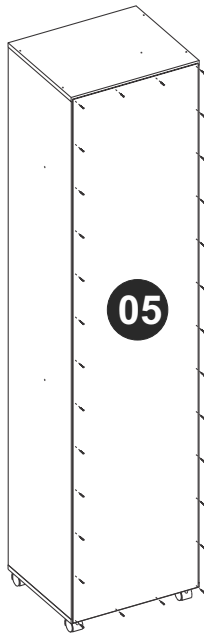

PASSO 9 / STEP 9 / PASO 9

Fixe a peça 05 ao móvel utilizando a ferragem EF 000168.
 Fix piece 05 at the furniture using hardware EF 000168.
 Fije la pieza 05 al mueble utilizando el herraje EF 000168.

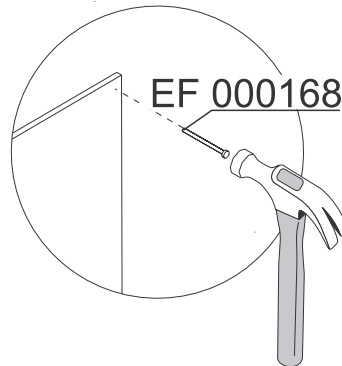

EF 000168

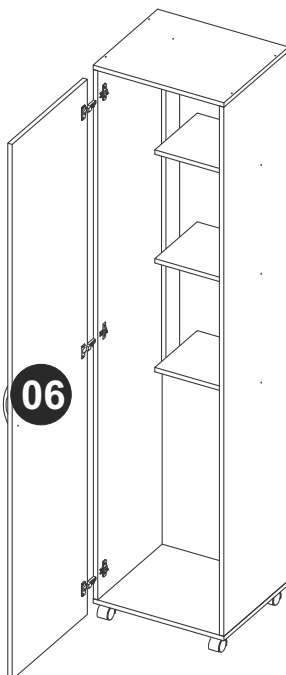

PASSO 10 / STEP 10 / PASO 10

Fixe as peças 06 ao móvel montado.
 Fix pieces 06 at the assembled furniture.
 Fije las piezas 06 al mueble armado.

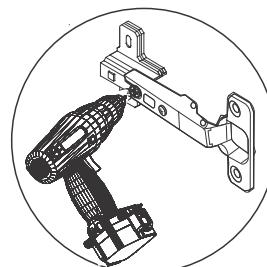

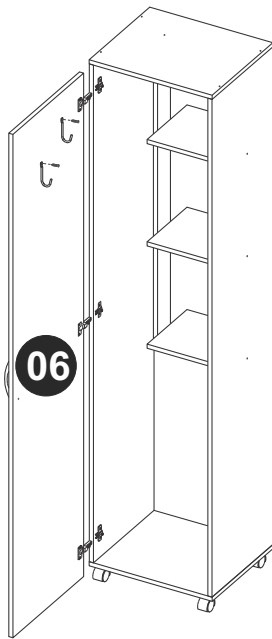

PASSO 11 / STEP 11/ PASO 11

Fixe a ferragem EF 000344 dentro do móvel utilizando a ferragem EF 000248.
 Attach hardware EF 000344 inside the furniture using hardware EF 000248.
 Fije el herraje EF 000344 dentro del mueble utilizando el herraje EF 000248.

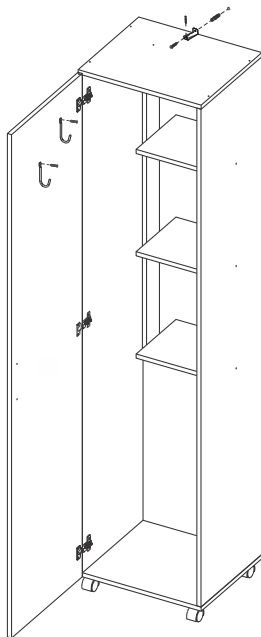
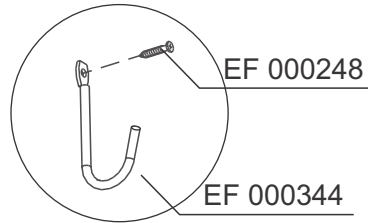

PASSO 12 / STEP 12 / PASO 12

Use o parafuso EF 000248 para fixar a ferragem EF 000529 ao móvel.
 Use hardware EF 000248 to fix the hardware EF 000529 at the furniture.
 Utilice el herraje EF 000248 para fijar el herraje EF000529 al mueble.

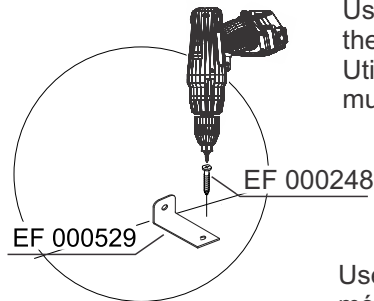

Use as ferragens EF 000246 e EF 000016 para fixar o móvel na parede.
 Use hardwares EF 000246 and EF 000016 for fixing the furniture on the wall.
 Utilice los herrajes EF000246 y EF000016 para fijar el mueble en la pared.

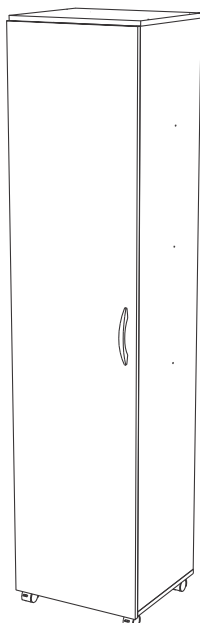
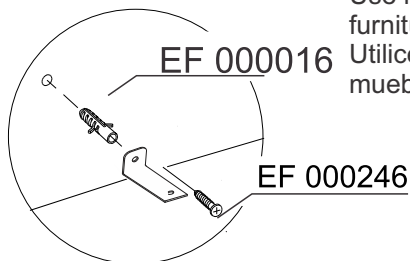

PASSO 13 / STEP 13 / PASO 13

Use o giz para dar o acabamento final ao produto.
 Use os tapa furos para cobrir os parafusos aparentes.
 Use the chalk to give the final finish on the product.
 Use stickers to cover apparent screws.
 Utilice la tiza para dar el acabado final al producto.
 Utilice los tapa huecos para cubrir los tornillos aparentes.

