

**MANUAL DE MONTAGEM
ASSEMBLY INSTRUCTIONS
INSTRUCCIONES DE MONTAJE**

COD BR: BF 11

Dimensões e ferramentas
 Dimensions and tools
 Dimensiones y herramientas

Dimensões:

L: 540 A: 800 P: 355 mm

Dimensions:

W: 21.25 H: 31.49 D: 13.97 inches

Dimensiones:

L: 540 A: 800 P: 355 mm



Espaço para forno:

L: 510 A: 295 P: 340 mm

Oven space:

W: 20.07 H: 11.61 D: 13.38 inches

Espacio para el horno:

L: 510 A: 295 P: 340 mm

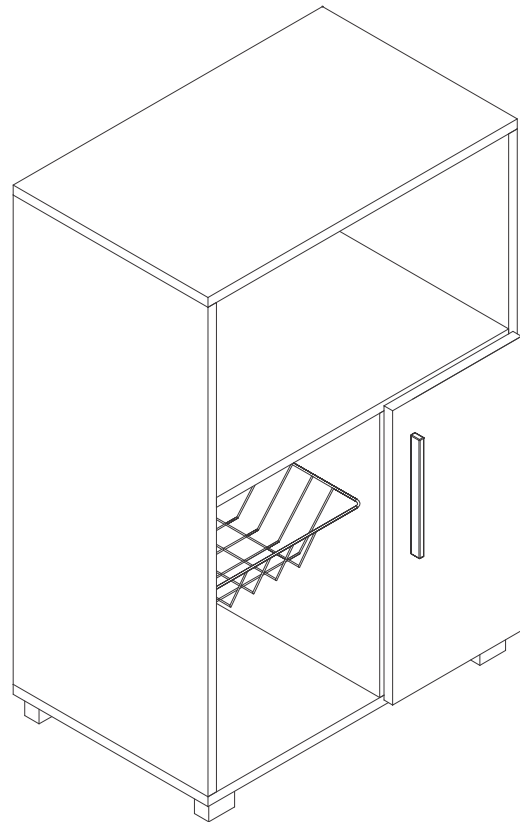

Limpeza
 Cleanig
 Limpieza



Pano levemente umedecido com água, seguido de pano seco, não utilizar produtos químico ou abrasivos.
 Slightly dampened cloth and after a dry cloth, do not use chemicals or abrasives.
 Solamente utilizar un paño húmedo y después un paño seco, no utilice productos químicos o abrasivos.

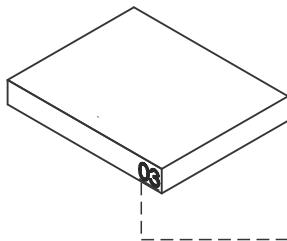

UTILIZE ALCOOL APENAS PARA REMOVER O NUMERO DAS PEÇAS
USE ALCOHOL ONLY TO REMOVE PART NUMBERS
UTILICE ALCOHOL SOLAMENTE PARA ELIMINAR EL NUMERO DE LAS PIEZAS

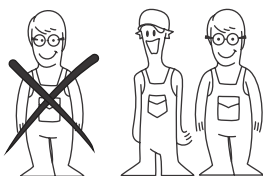

Para facilitar a montagem, utilize uma parafusadeira elétrica.
 To improve assembly, use an eletronic screwdriver.
 Para facilitar el armado, utilice un destornillador eléctrico.

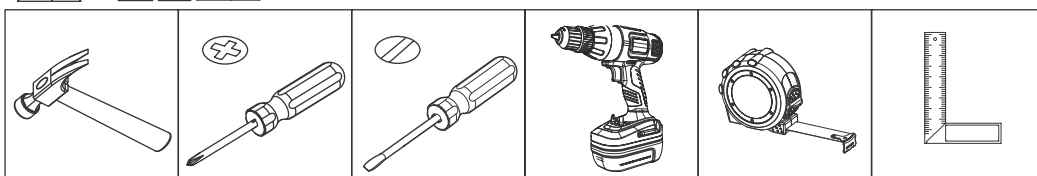

COD BR: BF 11

PEÇA	DESCRIÇÃO	QUANT.
001	LATERAL DIREITA	1
002	LATERAL ESQUERDA	1
003	TAMPO	1
004	PRATELEIRA	1
005	COSTA	1
006	PORTA	1
007	BASE	1
008	DIVISÓRIA	1

PART	DESCRIPTION	QTY
001	RIGHT SIDE	1
002	LEFT SIDE	1
003	TOP	1
004	SHELF	1
005	BACK	1
006	DOOR	1
007	BASE	1
008	PARTITION	1

PIEZA	DESCRIPCIÓN	CANTIDAD
001	LATERAL DERECHA	1
002	LATERAL IZQUIERDA	1
003	TAPA	1
004	REPISA	1
005	REVÉS	1
006	PUERTA	1
007	BASE	1
008	PARTICIÓN	1

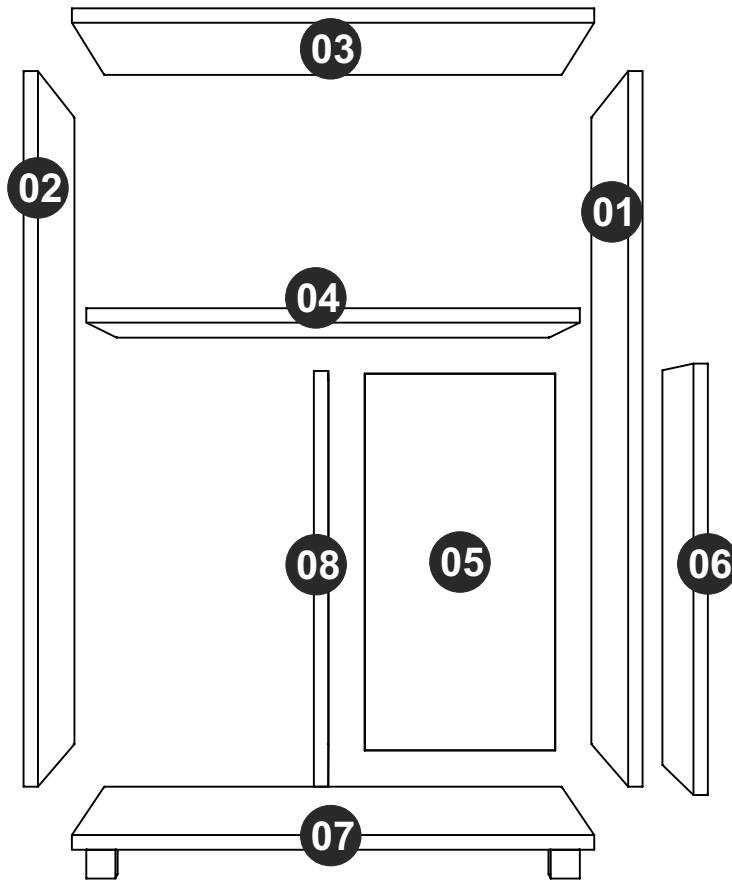



EF 000094 X 2

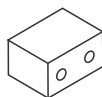

PÉS x 4
FEET x 4
PIES x 4



EF 000106 x 12
3,5X14 CC



EF 000033 x 16



EF 000168 X 15
10X10 C/C



EF 000216 X 2



EF 000008 X 1



GIZ x 01
CHALK x 01
TIZA x 01



EF 000132 X 5
4X50 CC



EF 000024 X 2

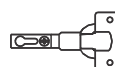

EF 000044 X 2

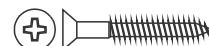

EF 000381 x 2
3X25 CF

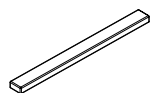

PUXADOR x 1
HANDLE x 1
MANIJA x 1



EF 000683 x 4



EF 000404 x 8
3,5X 24 CC

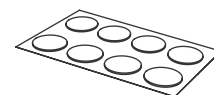

TAPA FUROS x 2
STICKER x 2
TAPAS PLÁSTICAS x 2



CESTA x 1
BASKET x 1
CESTA x 1

Utilize para medir as ferragens.

Utilice para medir el herraje.

Use for measuring the hardware.

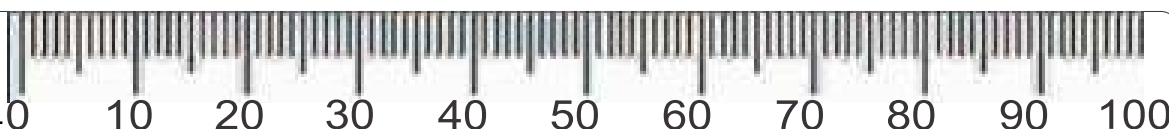

Garantia (exclusivo para o Brasil/exclusivo de Brasil/exclusive to Brazil):

A garantia dos produtos fabricados pela BRV Móveis, abrange eventuais defeitos-vícios de fabricação, no prazo estabelecido pelo código de Defesa do Consumidor, em seu artigo 26.II. o qual prevê a garantia de 90 (noventa) dias.

A = 7KG - 15.43LB

B = 6KG - 13.22LB

C = 2KG - 4.40LB

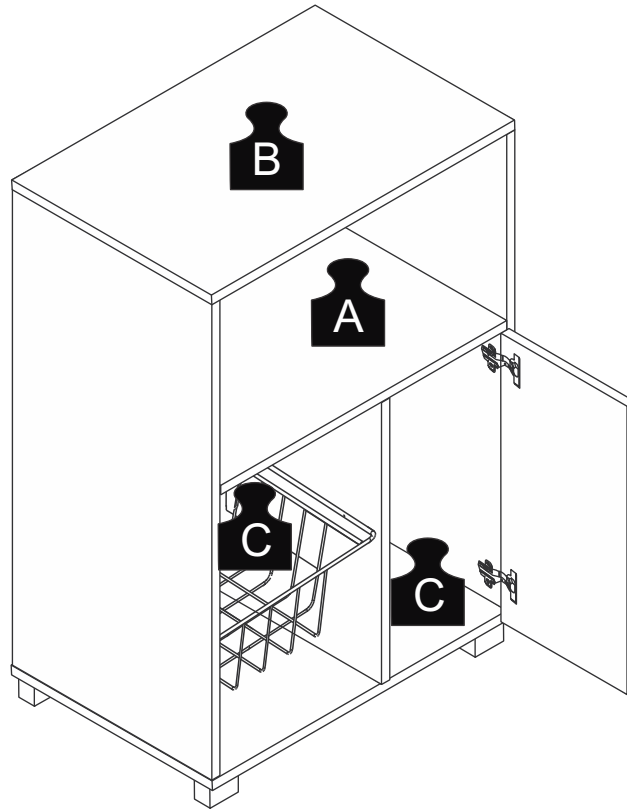

PASSO 1 / STEP 1 / PASO 1

Insira a ferragem EF 000033 na peça 02, 04 e 08.
Insert hardware EF 000033 in piece 02, 04 and 08.
Añade el herraje EF 000033 en la pieza 02, 04 y 08.

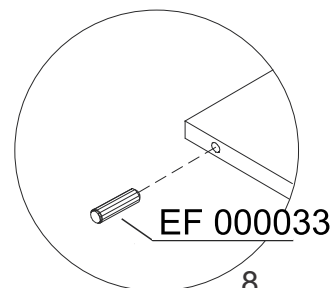
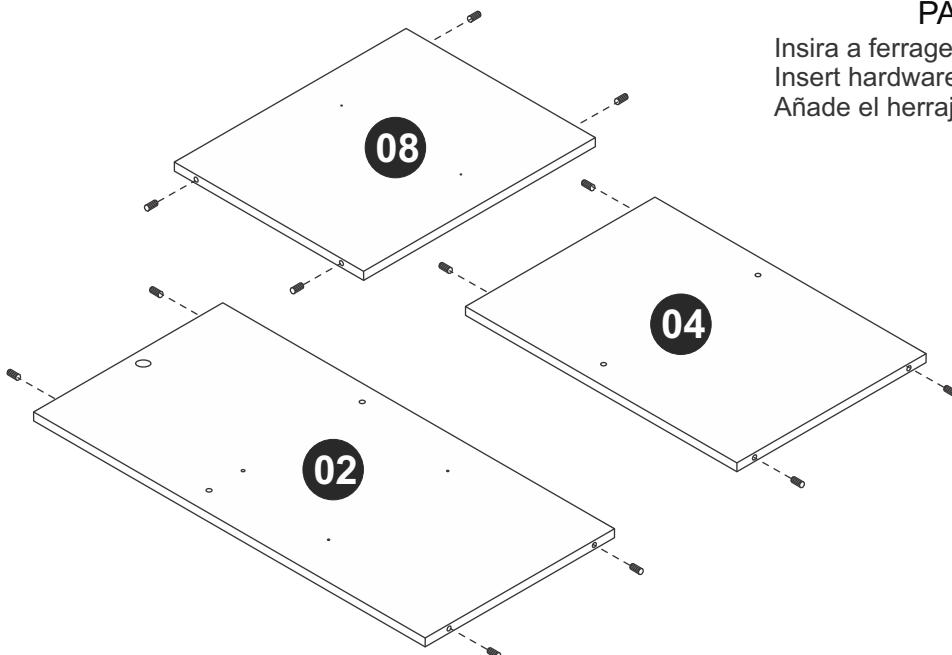

PASSO 2 / STEP 2 / PASO 2

Fixe a ferragem EF 000024 usando a ferragem EF 000106 na peça 01.
Fix hardware EF 000024 using hardware EF 000106 into piece 01.
Fije el herraje EF 000024 utilizando el herraje EF 000106 en la pieza 01.

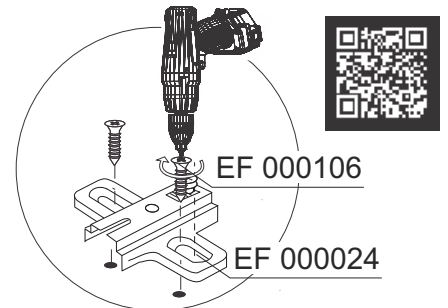
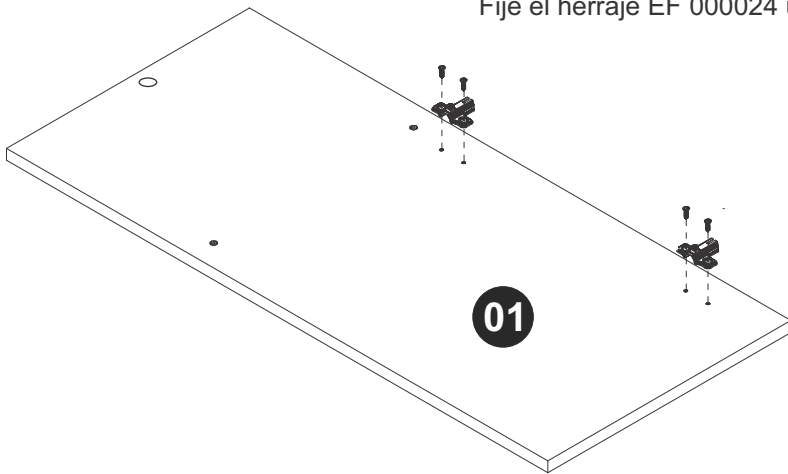

PASSO 3 / STEP 3 / PASO 3

Fixe a ferragem EF 000044 na peça 06 utilizando a ferragem EF 000106.
Fixe o puxador usando a ferragem EF 000381.
Attach hardware EF 000044 on piece 06 using hardware EF 000106. Attach the handle using hardware EF 000381.
Fije el herraje EF 000044 en la pieza 06 utilizando el herraje EF 000106.
Fije la manija utilizando el herraje EF 000381.

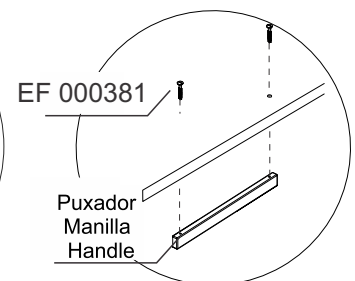
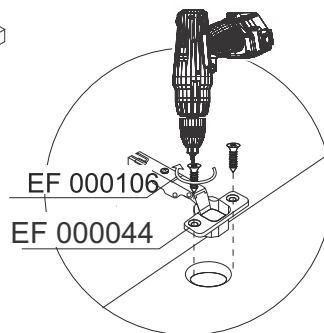
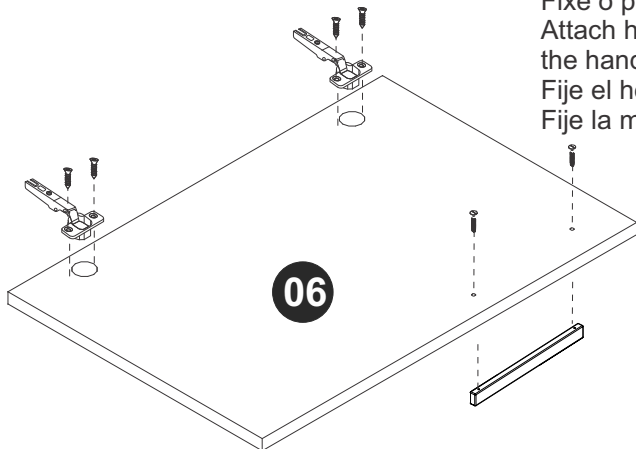

PASSO 4 / STEP 4 / PASO 4

Fixe a ferragem EF 000094 na peça 03.
Fix hardware EF 000094 in piece 03.
Fije el herraje EF 000094 en la pieza 03.

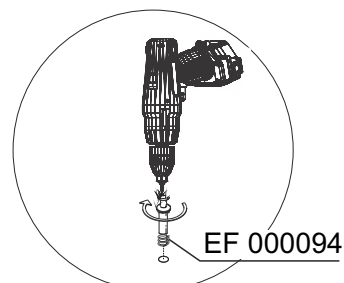
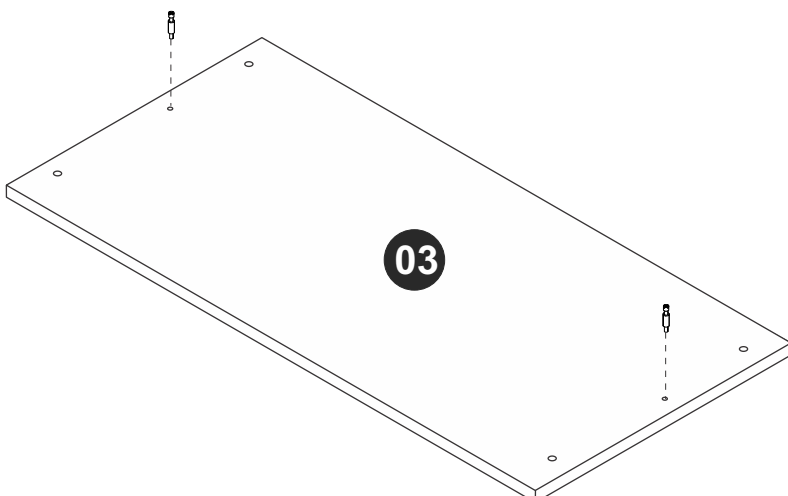

PASSO 5 / STEP 5 / PASO 5

Conecte as peças 01, 02, 04 e 08, utilizando a ferragem EF 000132.
Connect pieces 01, 02, 04 and 08, using hardware EF 000132.
Junte las piezas 01, 02, 04 y 08, utilizando el herraje EF 000132.

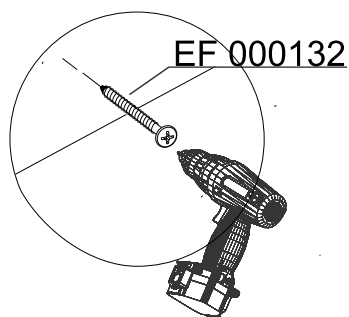
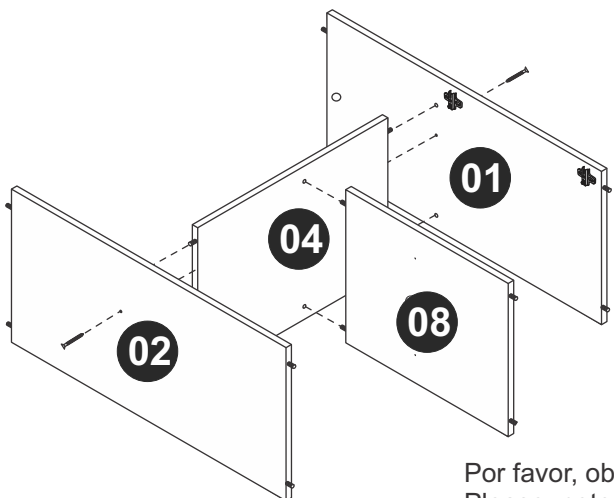

EF 000024

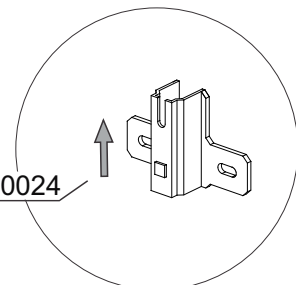

Por favor, observe a posição da ferragem EF 000024
Please, note hardware EF 000024 position.
Por favor, observe la posición del herraje EF000024.

PASSO 6 / STEP 6 / PASO 6

Conecte a peça 03, insira a ferragem EF 000216 e gire para apertar.
Connect piece 03, insert hardware EF 000216 and turn to tighten.
Junte la pieza 03, añade el herraje EF 000216 y gire para apretar.

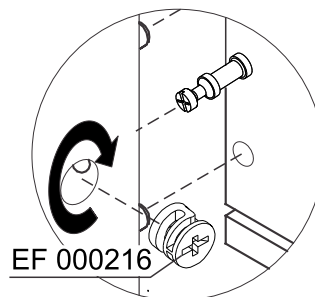
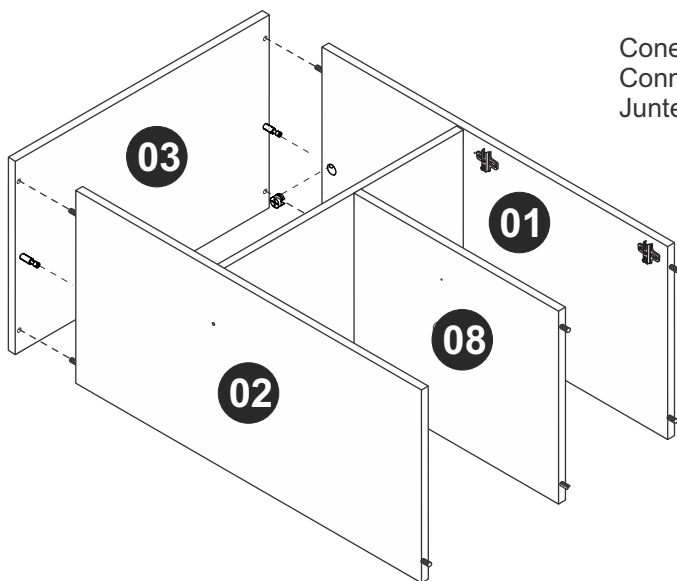

EF 000216

EF 000024

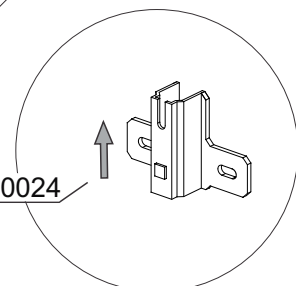

Por favor, observe a posição da ferragem EF 000024
Please, note hardware EF 000024 position.
Por favor, observe la posición del herraje EF000024.

PASSO 7 / STEP 7 / PASO 7

Conecte a peça 07 utilizando a ferragem EF 000132.
Connect pieces 07 using hardware EF 000132.
Junte la pieza 07 utilizando el herraje EF 000132.

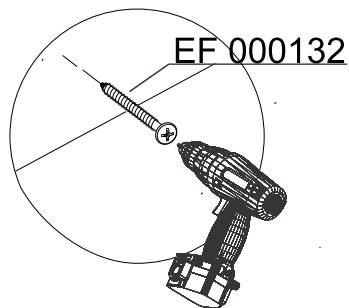
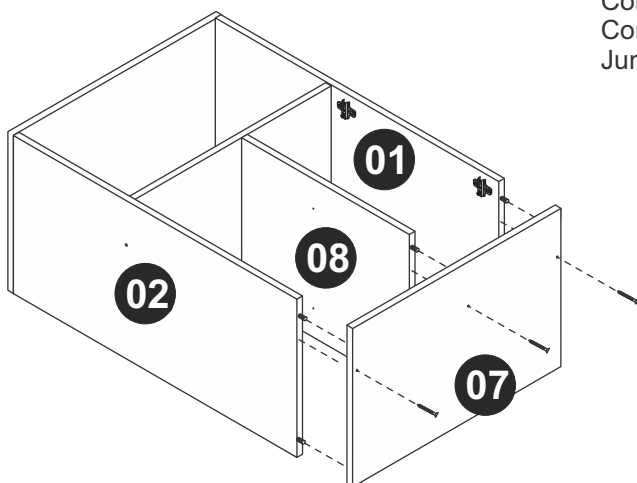

EF 000132

EF 000024

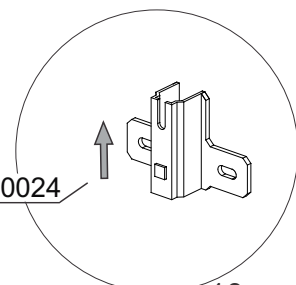

Por favor, observe a posição da ferragem EF 000024
Please, note hardware EF 000024 position.
Por favor, observe la posición del herraje EF000024.

PASSO 8 / STEP 8 / PASO 8

Utilize a ferragem EF 000404 para fixar os pés nas pré marcações.
Use hardware EF 000404 to attach the feet into predrilled holes.
Utilice el herraje EF 000404 para fijar los pies en los agujeros pré hechos.

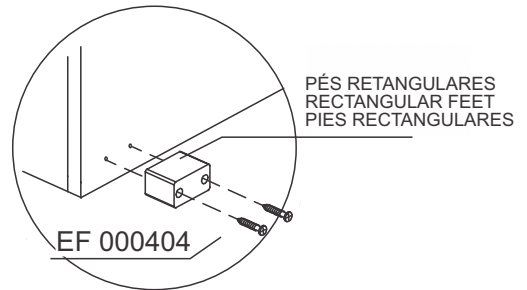
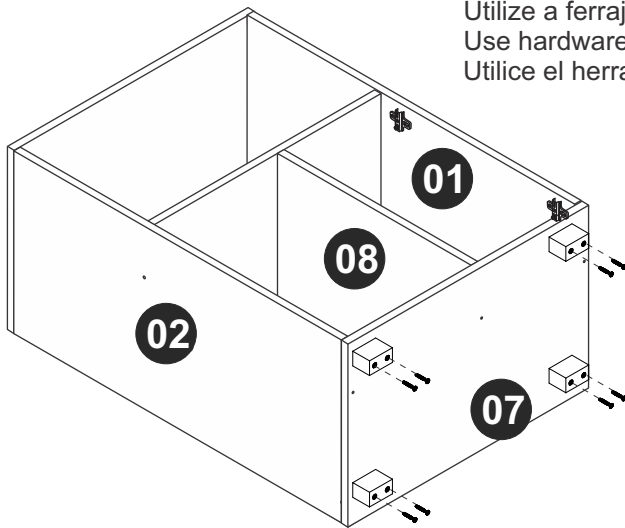

PASSO 9 / STEP 9 / PASO 9

Fixe a peça 05 ao móvel utilizando a ferragem EF 000168.
Fix piece 05 at the furniture using hardware EF 000168.
Fije la pieza 05 al mueble utilizando el herraje EF 000168.

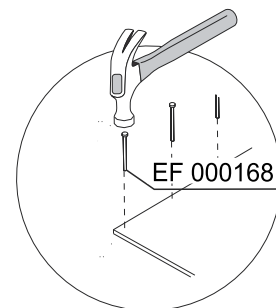
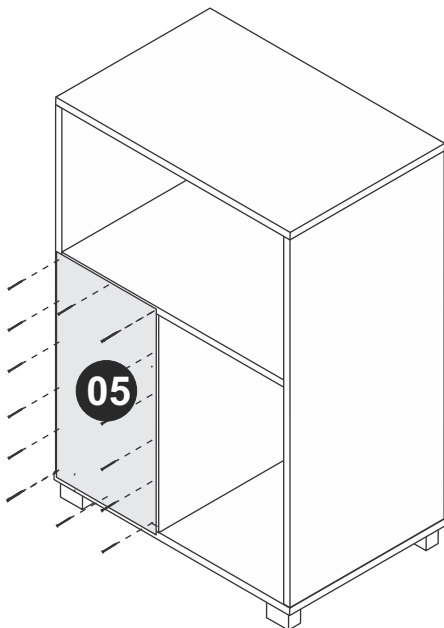

PASSO 10 / STEP 10 / PASO 10

Conecte a peça 06 ao móvel montado.
Connect piece 06 to the assembled furniture.
Junte la pieza 06 al mueble armado.

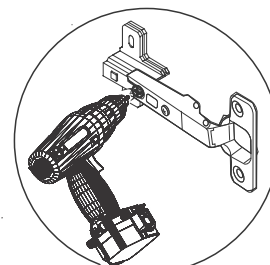
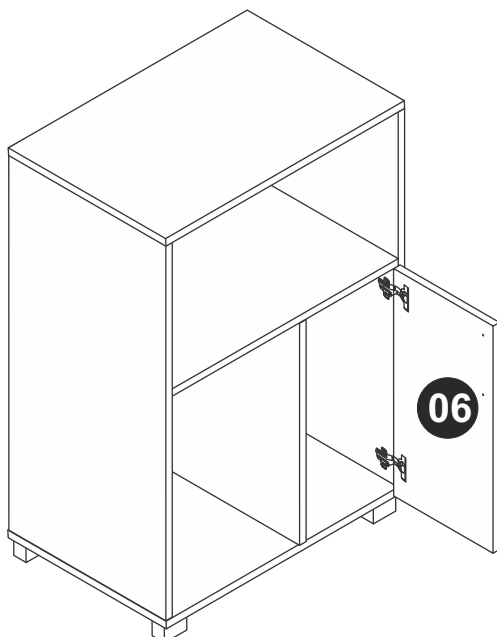

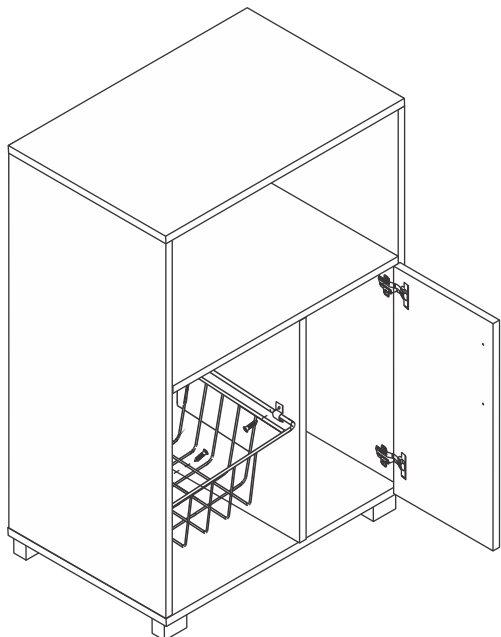

PASSO 11 / STEP 11 / PASO 11

Utilize as ferragens EF 000683 e EF 000106 para fixar a cesta.
Use hardware EF 000683 and EF 000106 to attach the basket.
Utilice los herrajes EF 000683 y EF 000106 para fijar la cesta.

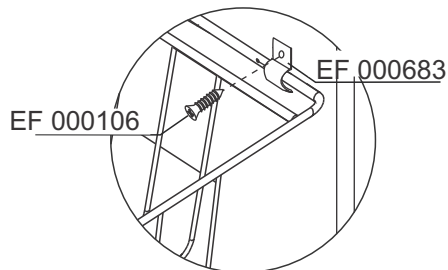

PASSO 12 / STEP 12 / PASO 12

Use os tapa furos para cobrir os parafusos aparentes.
Use o giz para dar o acabamento final ao produto.
Use stickers to cover apparent screws.
Use the chalk to give the final finish on the product.
Utilice los tapa huecos para cubrir los tornillos aparentes.
Utilice la tiza para dar el acabado final al producto.

