

**MANUAL DE MONTAGEM  
ASSEMBLY INSTRUCTIONS  
INSTRUCCIONES DE MONTAJE**

**COD BR: BR 363**



# Sumário Summary Resumen

Introdução Introduction Introducción	.....	3
Antes de começar Before starting Antes de comenzar	.....	4
Evite acidentes Avoid accidents Evitar accidentes	.....	4
Dimensões e ferramentas Dimensions and tools Dimensiones y herramientas	.....	5
Identificação das peças Identifying parts Identificación de las piezas	.....	6
Acessórios incluídos na caixa Hardware included in box Accesorios incluidos en la caja	.....	7
Montagem do móvel Furniture assembly Montaje del mueble	.....	8

## Introdução Introduction Introducción

Leia atentamente este manual e siga os passos indicados para que o produto não perca a garantia e também para uma perfeita montagem.

Read this manual and follow the steps in order to keep the guarantee and also for the perfect fit.

Lea este manual y siga los pasos para que el producto no pierda la garantía y también para el ajuste perfecto.

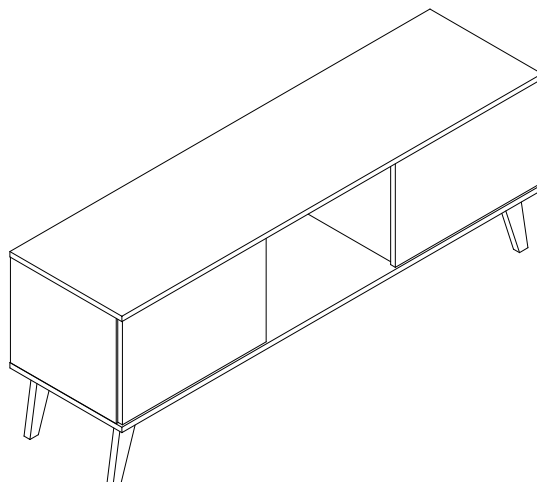

## Antes de começar Before starting Antes de comenzar

Antes de começar a montagem prepare o ambiente, deixando-o completamente limpo e com bom espaço para iniciar o trabalho.

Prepare the room before starting the assembly, leaving it completely clean and the area in good condition to start the work.

Antes de comenzar el montaje preparar el ambiente, dejándolo completamente limpio y con bueno espacio para comenzar el trabajo.

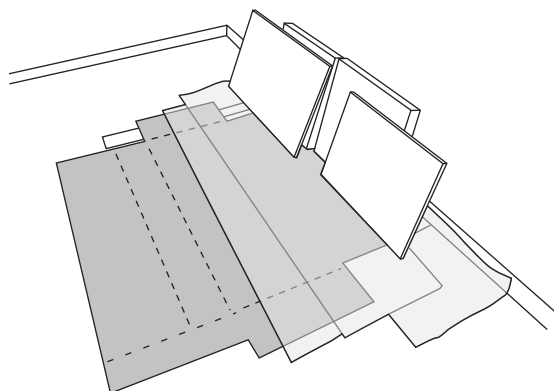

Utilize o papelão da própria embalagem para separar e apoiar as peças retiradas das caixas.

Use the cardboard of the packaging to separate and support the parts removed from the boxes.

Utilice el cartón de la embalaje para separar y apoyar las piezas desmontadas de las cajas.

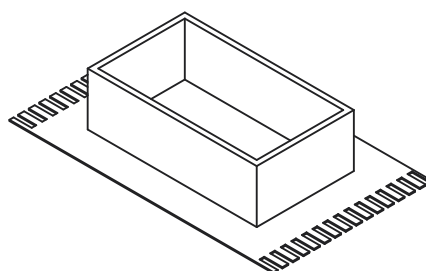

Forre a área de montagem com um cobertor ou tapete. Assim, você evita avarias nas peças durante o processo de montagem.

Cover the assembly area with a blanket or carpet to avoid damaging the parts during the assembly process.

Cubrir la zona de ensamble con una manta o alfombra. De este modo, se evitan daños en las piezas durante el proceso de montaje.



---

## Evite acidentes Avoid accidents Prevenir accidentes

Solicitamos observar atentamente as orientações de montagem como: fixação do produto na parede, colocação de cola em locais específicos necessários, o peso suportado pelo produto, etc...

We request you to carefully observe the assembly instructions as: fixing the product on the wall, adding glue in needed and specific places, product weight limit, etc.

Pedimos que lea atentamente las instrucciones, principalmente las informaciones de fijación del producto en la pared, colocación de pegamento en local específico y necesario, el peso soportado por el producto etc...

Não escale ou se apoie no móvel.

Do not climb or lean on the furniture.

No se suba ni se apoye en el mueble.

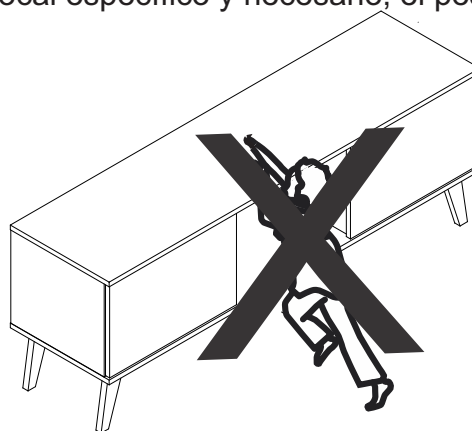

Dimensões e ferramentas  
Dimensions and tools  
Dimensiones y herramientas

Dimensões:

L: 1350 A: 544 P: 360 mm

Dimensions:

W: 53.14 H: 21.41 D: 14.17 inches

Dimensiones:

L: 1350 A: 544 P: 360 mm

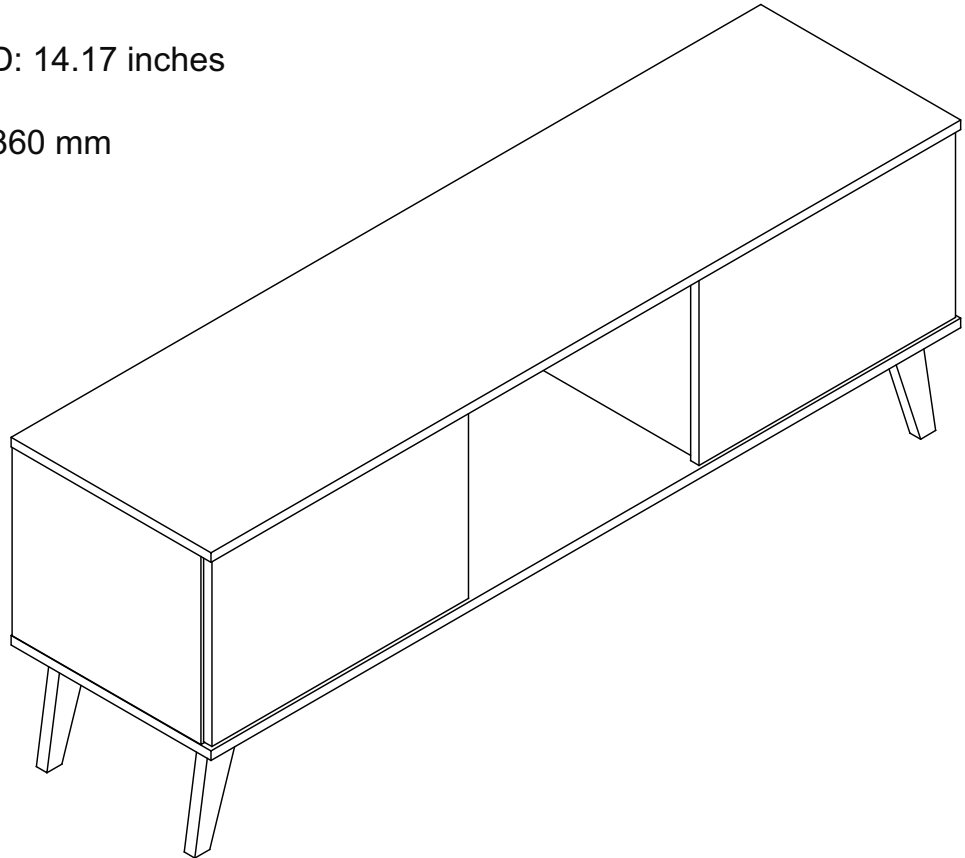

Limpeza  
Cleaning  
Limpieza

Pano levemente umedecido com água, seguido de pano seco, não utilizar produtos químico ou abrasivos.  
Slightly dampened cloth and after a dry cloth, do not use chemicals or abrasives.  
Solamente utilizar un paño húmedo y después un paño seco, no utilice productos químicos o abrasivos.

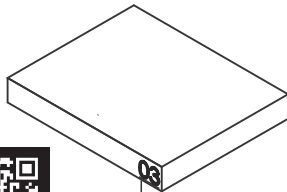

**UTILIZE ALCOOL APENAS PARA REMOVER O NUMERO DAS PEÇAS**  
**USE ALCOHOL ONLY TO REMOVE PART NUMBERS**  
**UTILICE ALCOHOL SOLAMENTE PARA ELIMINAR EL NUMERO DE LAS PIEZAS**

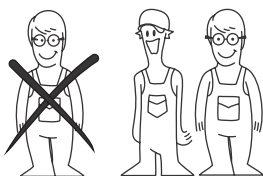

Para facilitar a montagem, utilize uma parafusadeira elétrica.  
To improve assembly, use an electronic screwdriver.  
Para facilitar el armado, utilice un destornillador eléctrico.

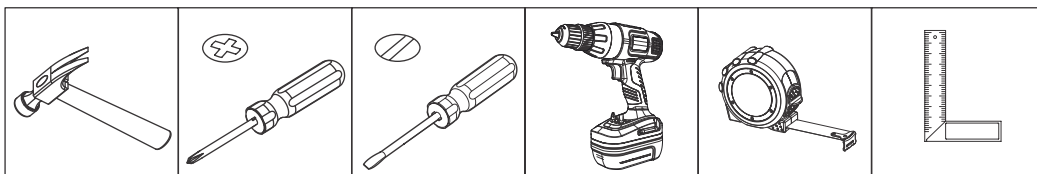

# COD BR: BR 363

PEÇA	DESCRIÇÃO	QUANT.
001	BASE	1
002	TAMPO	1
003	LATERAL ESQUERDA	1
004	LATERAL DIREITA	1
005	DIVISÓRIA ESQUERDA	1
006	DIVISÓRIA DIREITA	1
007	PRATELEIRA	2
008	PORTA ESQUERDA	1
009	PORTA DIREITA	1
010	COSTA	1
011	PÉS	4

PART	DESCRIPTION	QTY
001	BASE	1
002	TOP	1
003	LEFT SIDE	1
004	RIGHT SIDE	1
005	LEFT PARTITION	1
006	RIGHT PARTITION	1
007	SHELF	2
008	LEFT DOOR	1
009	RIGHT DOOR	1
010	BACK	1
011	FEET	4

PIEZA	DESCRIPCIÓN	CANTIDAD
001	BASE	1
002	TAPA	1
003	LATERAL IZQUIERDA	1
004	LATERAL DERECHA	1
005	PARTICIÓN IZQUIERDA	1
006	PARTICIÓN DERECHA	1
007	REPISA	2
008	PUERTA IZQUIERDA	1
009	PUERTA DERECHA	1
010	REVÉS	1
011	PIES	4

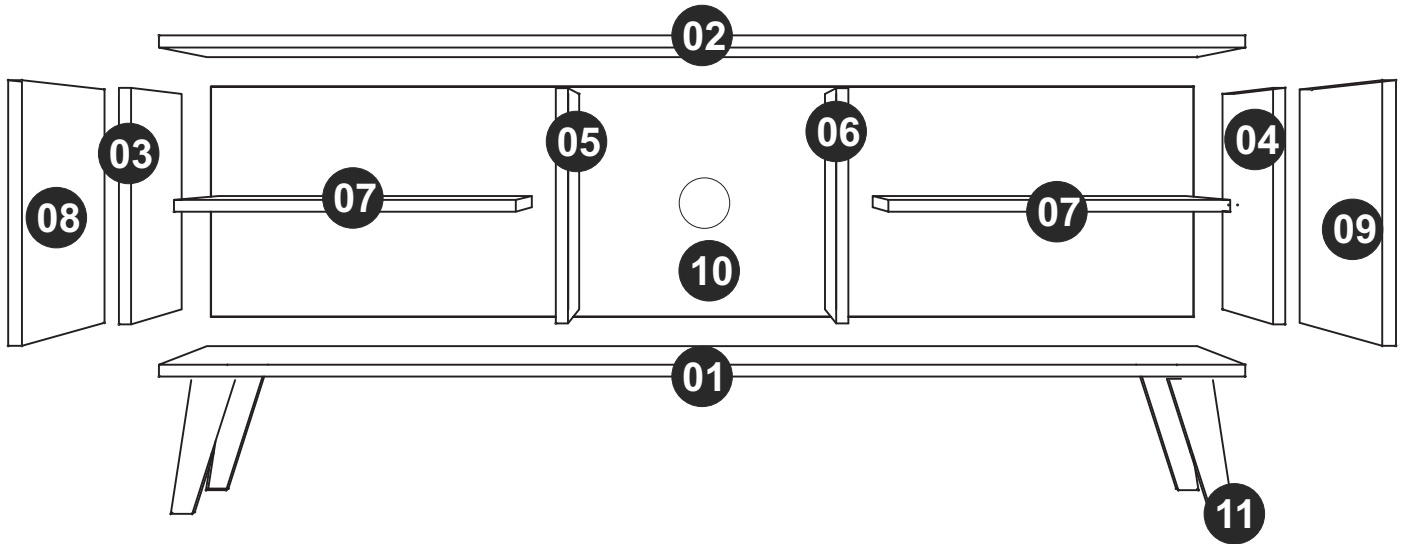

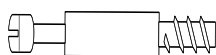

EF 000094 X 8



GIZ x 1  
CHALK x 1  
TIZA x 1



EF 000216 X 8



EF 000033 x 24  
8x30

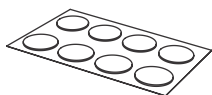

TAPA FUROS x 16  
STICKER x 16  
TAPAS PLÁSTICAS x 16



EF 000106 X 16  
3,5x14 CC



EF 000168 X 34  
10x10 C/C



EF 000107 x 16  
3,6X16 CC

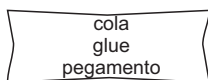

EF 000008 x 1



EF 000132 x 8  
4X50 CC

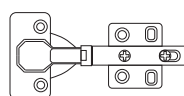

EF 000811 x 4

Utilize para medir as ferragens.

Utilice para medir el herraje.

Use for measuring the hardware.

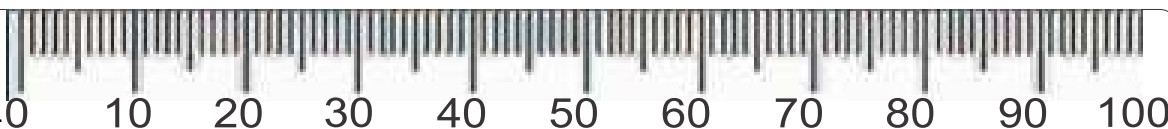

**Garantia (exclusivo para o Brasil/exclusivo de Brasil/exclusive to Brazil):**

A garantia dos produtos fabricados pela BRV Móveis, abrange eventuais defeitos-vícios de fabricação, no prazo estabelecido pelo código de Defesa do Consumidor, em seu artigo 26.II. o qual prevê a garantia de 90 (noventa) dias.

**A** = 17KG - 37.47LB

**B** = 5KG - 11.02LB

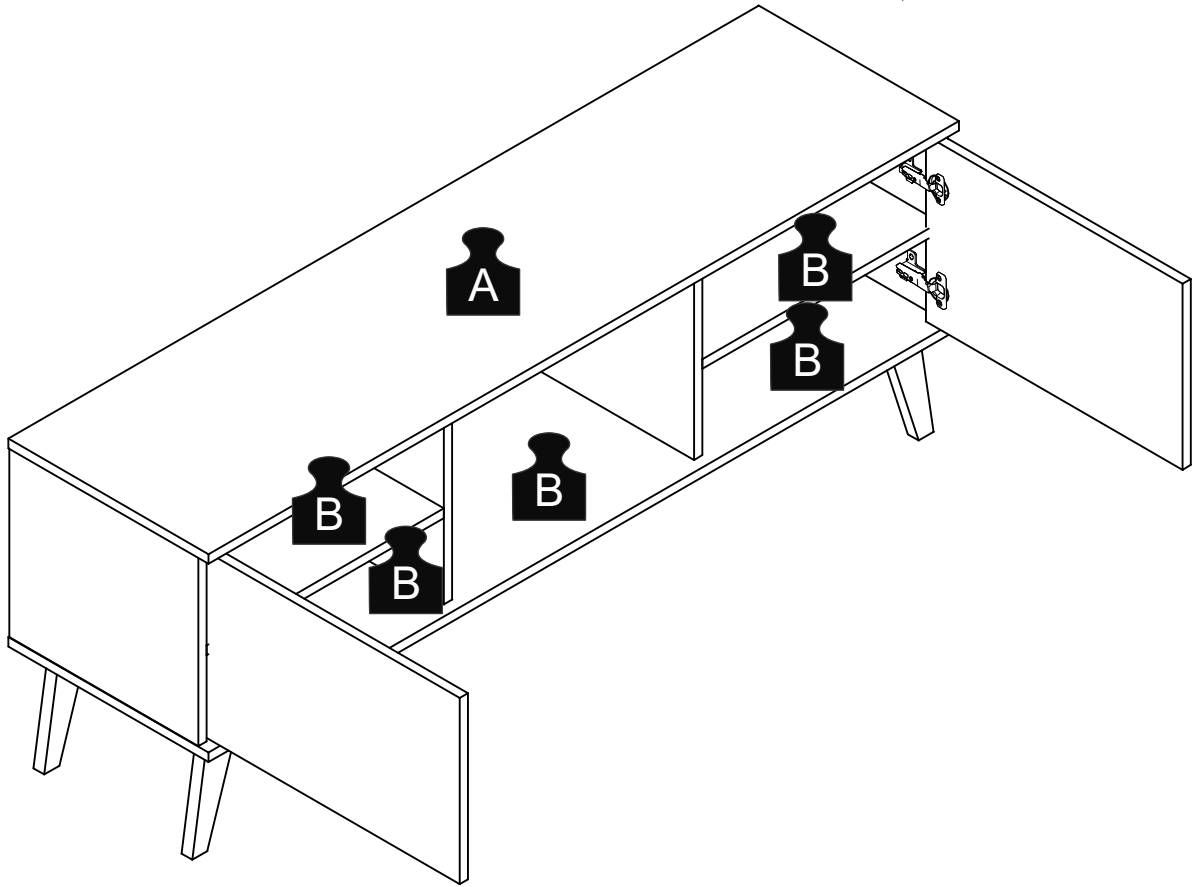

**PASSO 1 / STEP 1 / PASO 1**

Insira a ferragem EF 000094 na peça 02.  
Insert hardware EF 000094 into piece 02.  
Añade el herraje EF 000094 en la pieza 02.

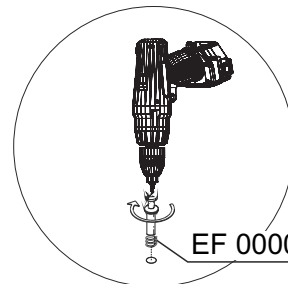
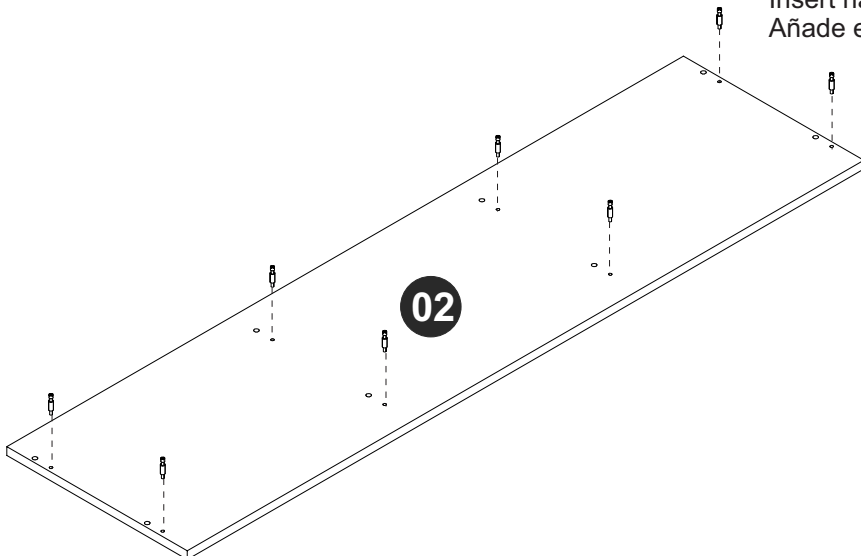

EF 000094



## PASSO 2 / STEP 2 / PASO 2

Insira a ferragem EF 000033 nas peças 03, 04, 05 e 06.  
Insert the hardware EF 000033 into pieces 03, 04, 05 and 06.  
Añade el herraje EF 000033 en las piezas 03, 04, 05 y 06.

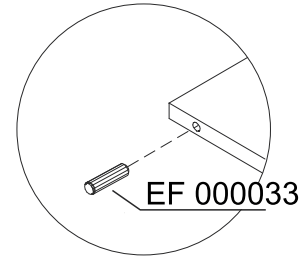
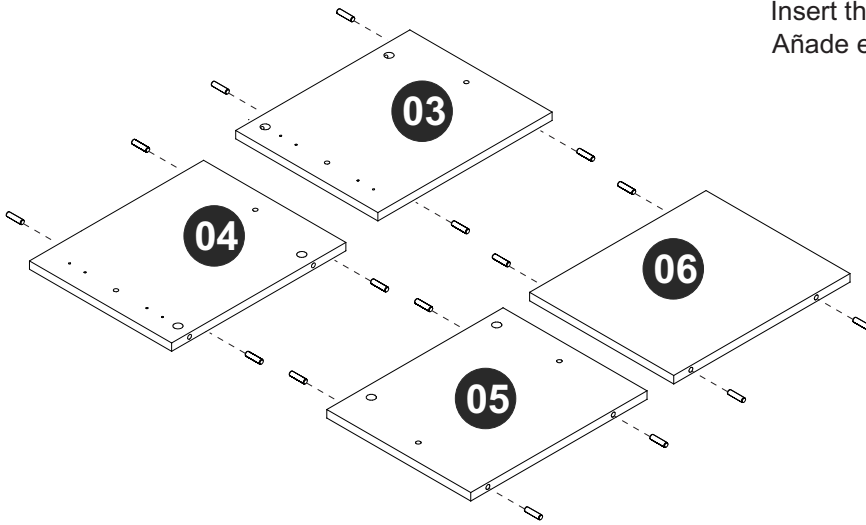

## PASSO 3 / STEP 3 / PASO 3

Utilize a cola (EF 000008) antes de inserir a ferragem EF 000033 nas peças 07.  
Use the glue (EF 000008) before connecting hardware EF 000033 into pieces 07.  
Utilice el pegamento (EF 000008) antes de añadir el herraje EF 000033 en las piezas 07.

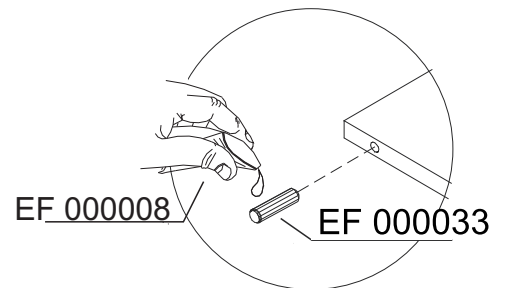
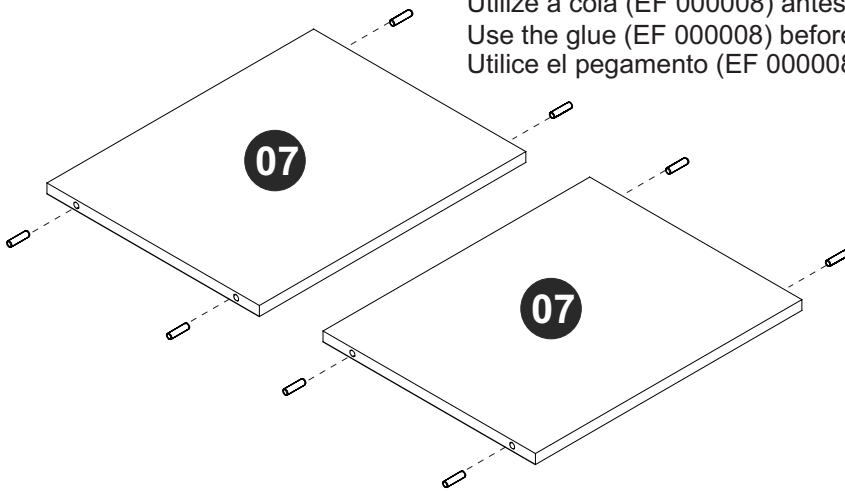

## PASSO 4 / STEP 4/ PASO 4

Fixe a ferragem EF 000811 nas peças 08 e 09 utilizando a ferragem EF 000106 .  
Attach hardware EF 000811 on pieces 08 and 09 using hardware EF 000106 .  
Fije el herraje EF 000811 en las piezas 08 y 09 utilizando el herraje EF 000106 .

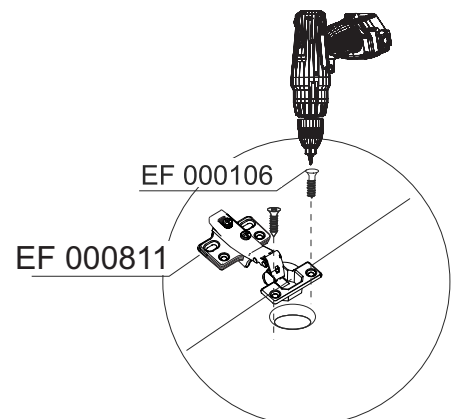
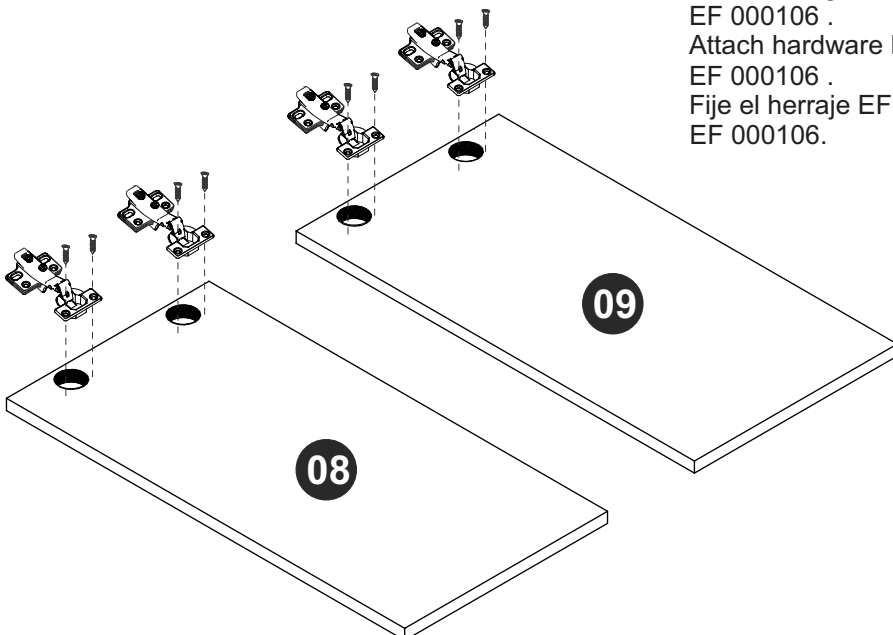

### PASSO 5 / STEP 5 / PASO 5

Utilize a cola antes de conectar as peças 04, 06 e 07 e as peças 03, 05 e 07.  
Use the glue before connecting pieces 04, 06 and 07 and pieces 03, 05 and 07.  
Utilice el pegamento antes de juntar las piezas 04, 06 y 07 y las piezas 03, 05 y 07.

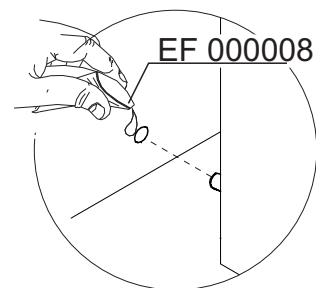
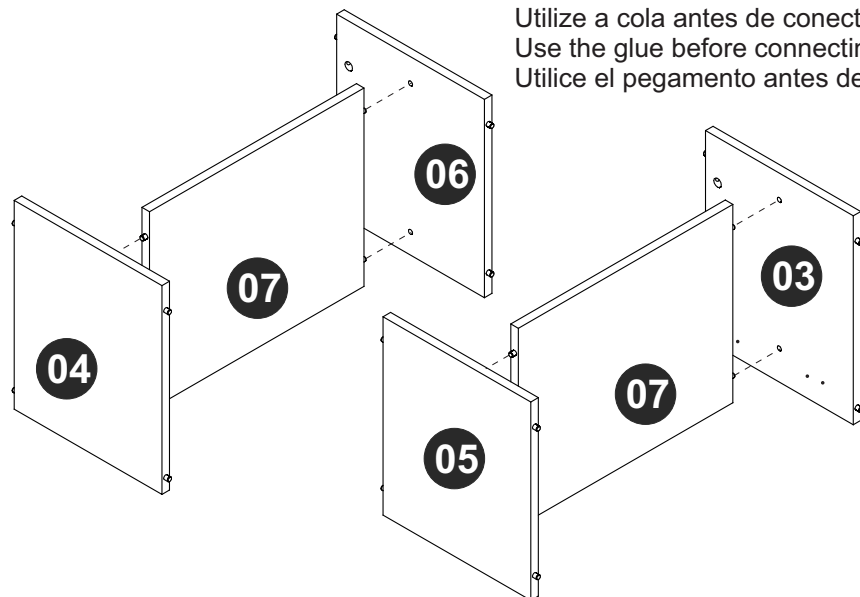

### PASSO 6 / STEP 6 / PASO 6

Conecte a peça 02 à parte montada no passo anterior, insira a ferragem EF 000216 e gire para apertar.  
Connect piece 02 to the part assembled in the previous step, insert hardware EF 000216 and turn to tighten.  
Junte las pieza 02 a la parte armada en el paso anterior, añade el herraje EF 000216 y gire para apretar.

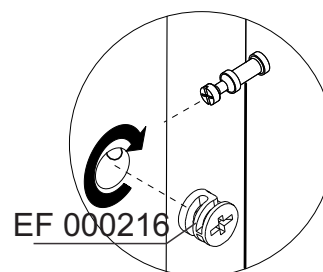
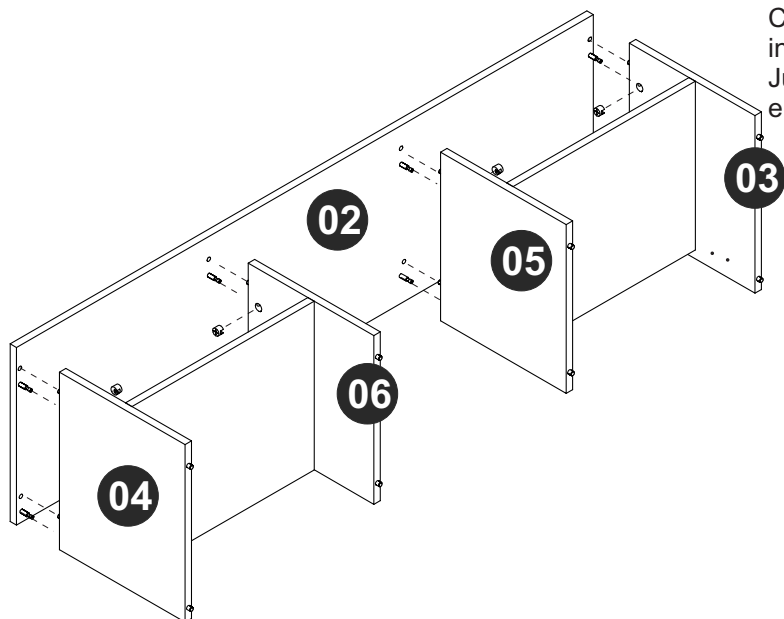

### PASSO 7 / STEP 7 / PASO 7

Fixe os pés na peça 01 utilizando a ferragem EF 000107.  
Attach the feet in piece 01 using hardware EF 000107.  
Fije los pies a la pieza 01 utilizando el herraje EF 000107.

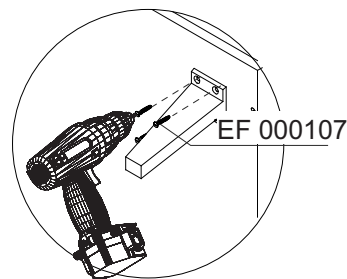
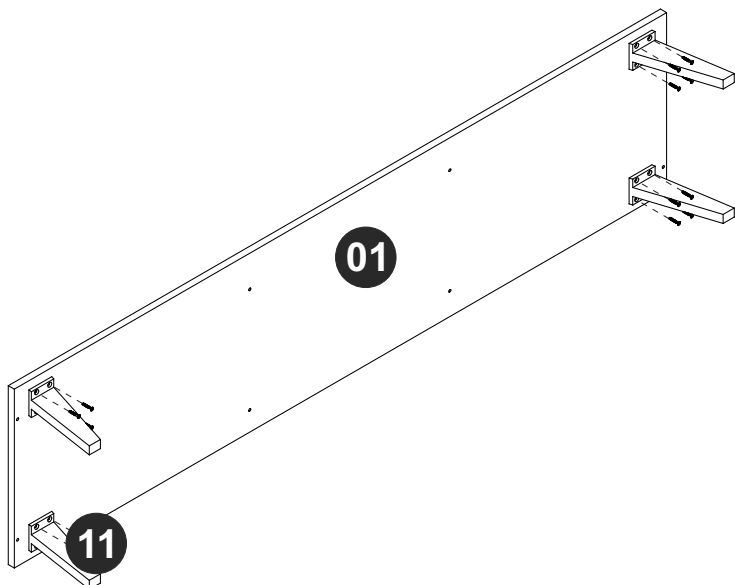

### PASSO 8 / STEP 8 / PASO 8

Conecte a peça 01 utilizando a ferragem EF 000132.  
Connect piece 01 using hardware EF 000132.  
Junte la pieza 01 utilizando el herraje EF 000132.

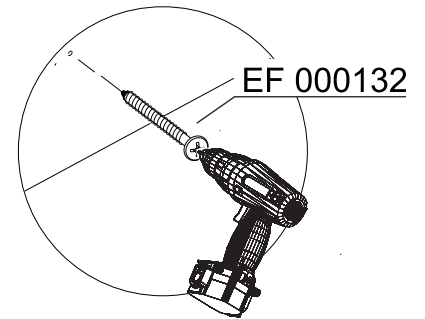
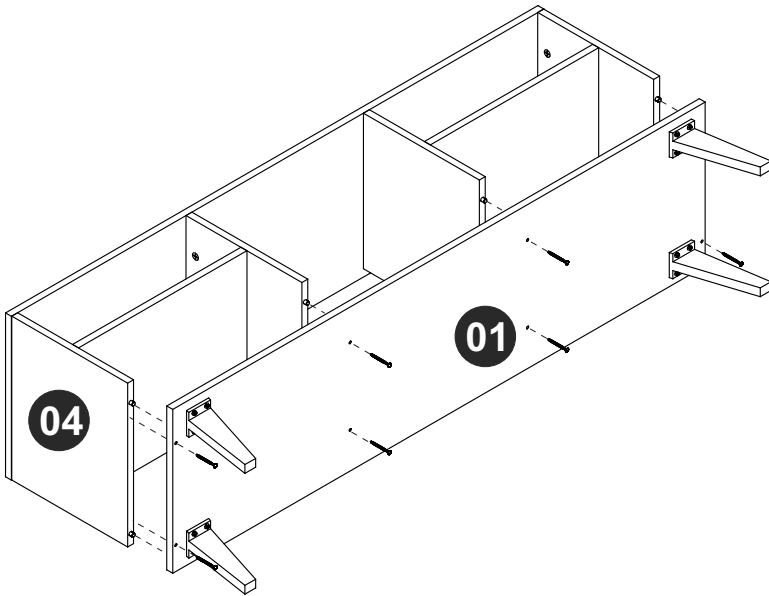

### PASSO 9 / STEP 9 / PASO 9

Fixe a peça 10 ao móvel utilizando a ferragem EF 000168.  
Fix piece 10 at the furniture using hardware EF 000168.  
Fije la pieza 10 al mueble utilizando el herraje EF 000168.

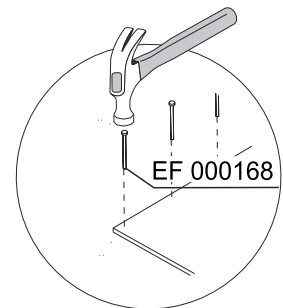
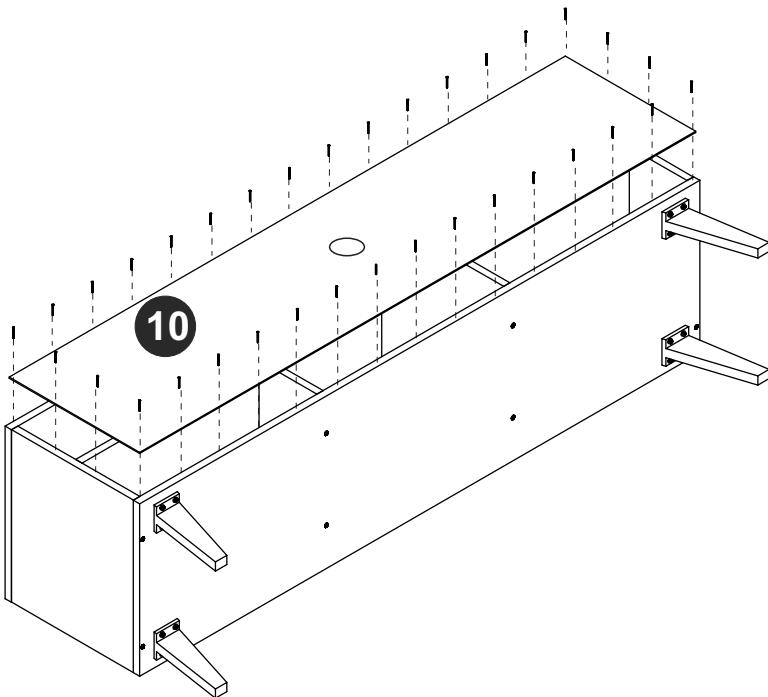

### PASSO 10 / STEP 10 / PASO 10

Fixe as peças 08 e 09 ao móvel montado utilizando a ferragem EF 000106.  
Attach pieces 08 and 09 at the assembled furniture using hardware EF 000106.  
Fije las piezas 08 y 09 al mueble armado utilizando el herraje EF 000106.

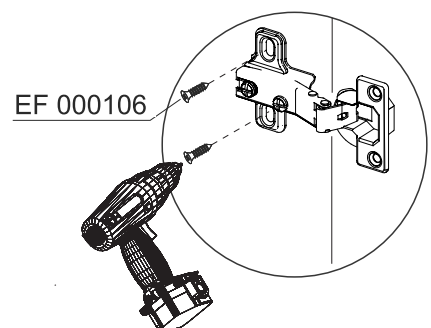
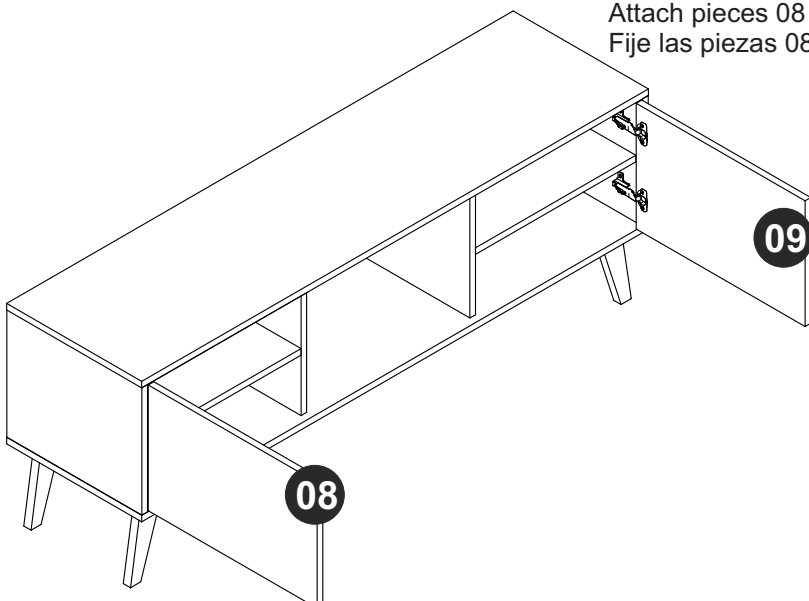

### PASSO 11 / STEP 11 / PASO 11

Use o giz para dar o acabamento final ao produto. Use os tapa furos para cobrir os parafusos aparentes.

Use the chalk to give the final finish on the product. Use stickers to cover apparent screws.

Utilice la tiza para dar el acabado final al producto. Utilice los tapa huecos para cubrir los tornillos aparentes.

