



MANUAL DE MONTAGEM
ASSEMBLY INSTRUCTIONS
INSTRUCCIONES DE MONTAJE

COD BR: BR 463

Dimensões e ferramentas
Dimensions and tools
Dimensiones y herramientas

Dimensões:

L: 1580 A: 500 P: 380 mm

Dimensions:

W: 62.20 H: 19.68 D: 14.96 inches

Dimensiones:

L: 1580 A: 500 P: 380 mm

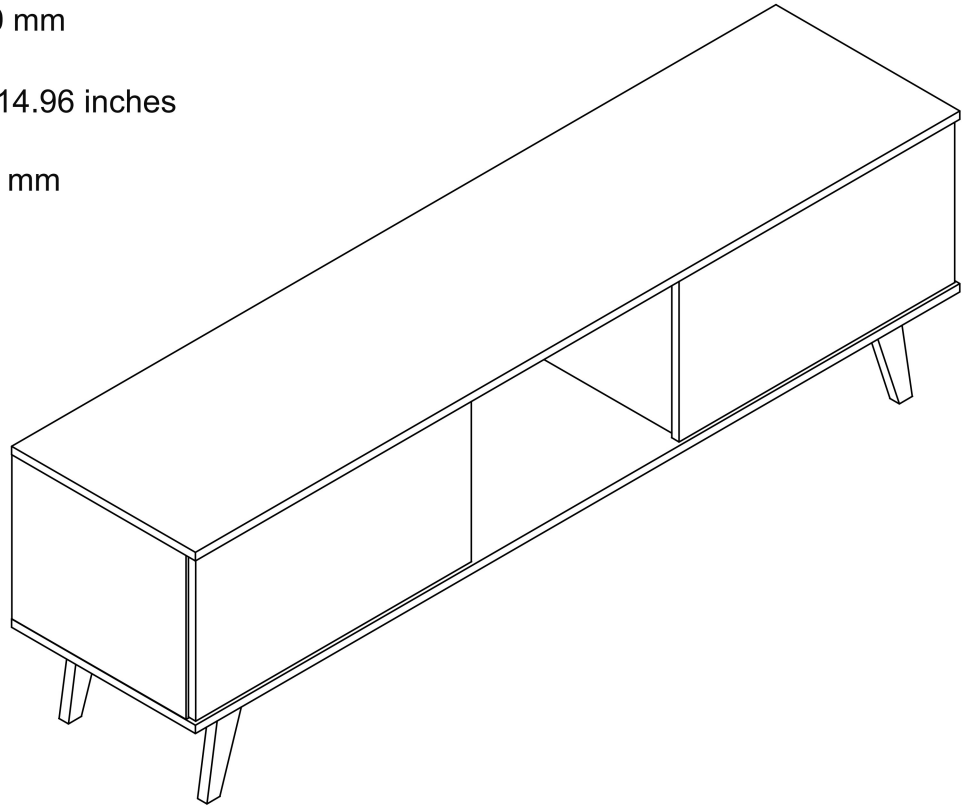

Limpeza
Cleaning
Limpieza

Pano levemente umedecido com água, seguido de pano seco, não utilizar produtos químico ou abrasivos.
Slightly dampened cloth and after a dry cloth, do not use chemicals or abrasives.
Solamente utilizar un paño húmedo y después un paño seco, no utilice productos químicos o abrasivos.

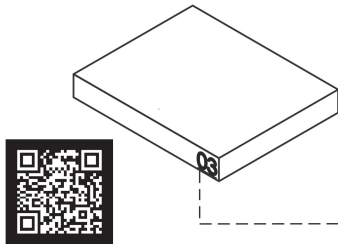

UTILIZE ALCOOL APENAS PARA REMOVER O NUMERO DAS PEÇAS
USE ALCOHOL ONLY TO REMOVE PART NUMBERS
UTILICE ALCOHOL SOLAMENTE PARA ELIMINAR EL NUMERO DE LAS PIEZAS

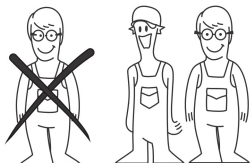

Para facilitar a montagem, utilize uma parafusadeira elétrica.
To improve assembly, use an electronic screwdriver.
Para facilitar el armado, utilice un destornillador eléctrico.

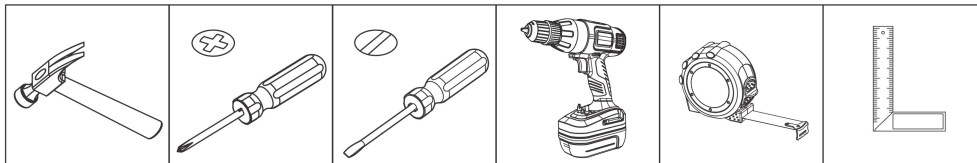

COD BR: BR 463

PEÇA	DESCRIÇÃO	QUANT.
001	BASE	1
002	TAMPO	1
003	LATERAL ESQUERDA	1
004	LATERAL DIREITA	1
005	DIVISÓRIA ESQUERDA	1
006	DIVISÓRIA DIREITA	1
007	PRATELEIRA	2
008	PORTA ESQUERDA	1
009	PORTA DIREITA	1
010	COSTA	1
011	PÉS	4

PART	DESCRIPTION	QTY
001	BASE	1
002	TOP	1
003	LEFT SIDE	1
004	RIGHT SIDE	1
005	LEFT PARTITION	1
006	RIGHT PARTITION	1
007	SHELF	2
008	LEFT DOOR	1
009	RIGHT DOOR	1
010	BACK	1
011	FEET	4

PIEZA	DESCRIPCIÓN	CANTIDAD
001	BASE	1
002	TAPA	1
003	LATERAL IZQUIERDA	1
004	LATERAL DERECHA	1
005	PARTICIÓN IZQUIERDA	1
006	PARTICIÓN DERECHA	1
007	REPISA	2
008	PUERTA IZQUIERDA	1
009	PUERTA DERECHA	1
010	REVÉS	1
011	PIES	4

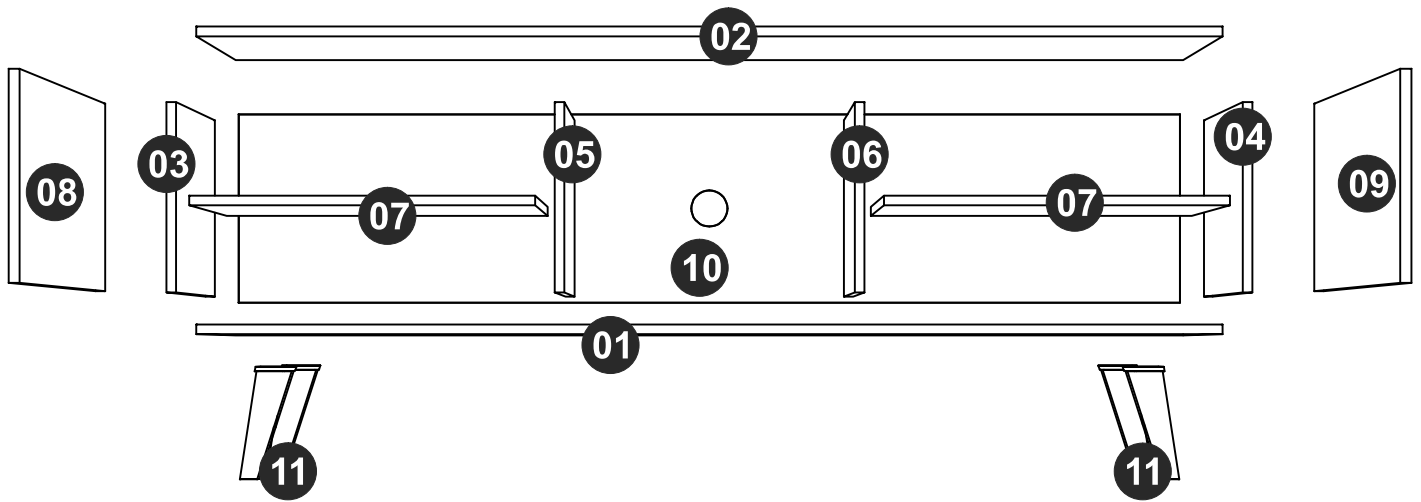



EF 000094 X 8



GIZ x 1
CHALK x 1
TIZA x 1



EF 000216 X 8



EF 000033 x 24
8x30

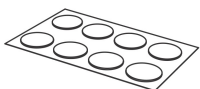

TAPA FUROS x 16
STICKER x 16
TAPAS PLÁSTICAS x 16



EF 000106 X 16
3,5x14 CC



EF 000168 X 38
10x10 C/C



EF 000107 x 16
3,5X16 CC



EF 000008 x 1



EF 000132 x 8
4X50 CC

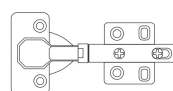

EF 000811 x 4

Utilize para medir as ferragens.

Utilice para medir el herraje.

Use for measuring the hardware.

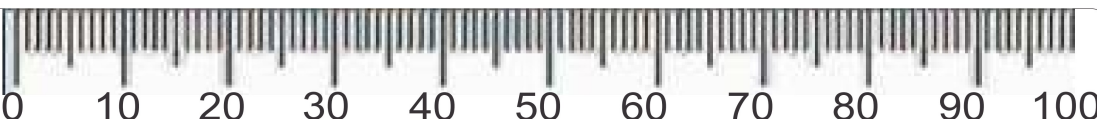

Garantia (exclusivo para o Brasil/exclusivo de Brasil/exclusive to Brazil):

A garantia dos produtos fabricados pela BRV Móveis, abrange eventuais defeitos-vícios de fabricação, no prazo estabelecido pelo código de Defesa do Consumidor, em seu artigo 26.II. o qual prevê a garantia de 90 (noventa) dias.

A = 23KG - 50.70LB

B = 7KG - 15.43LB

65"

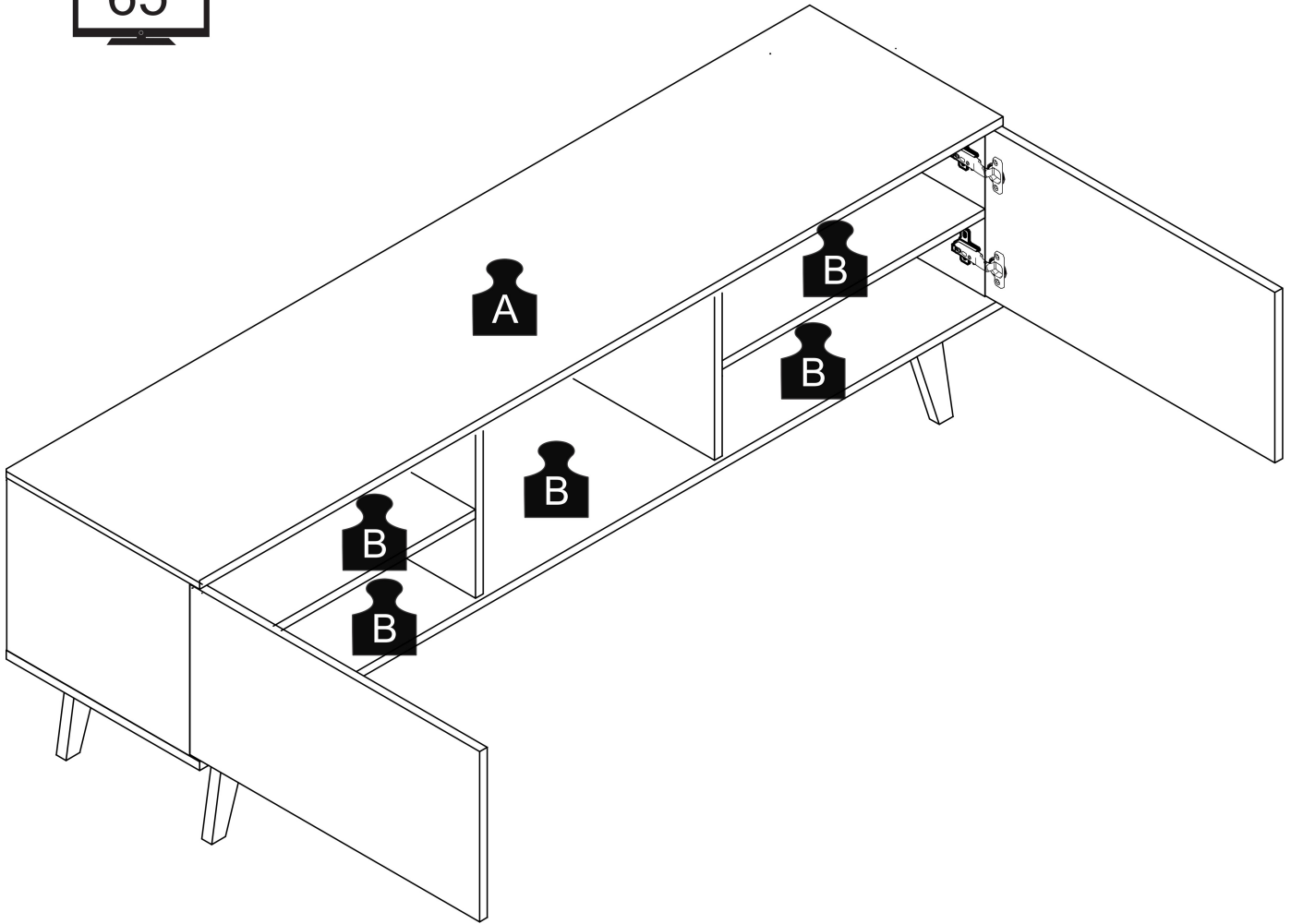

PASSO 1 / STEP 1 / PASO 1

Insira a ferragem EF 000094 na peça 02.
Insert hardware EF 000094 into piece 02.
Añade el herraje EF 000094 en la pieza 02.

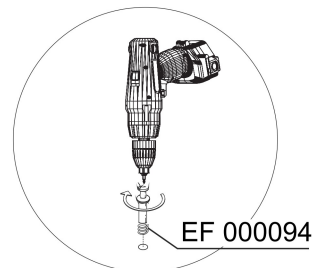
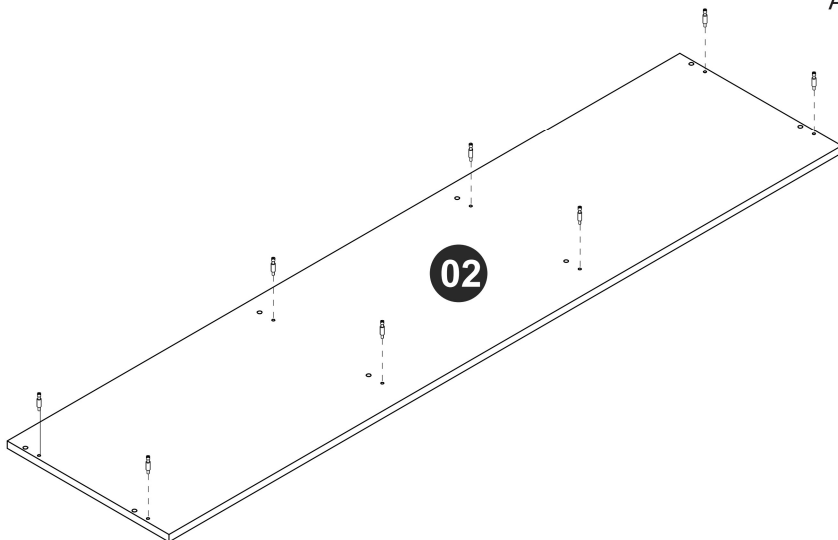

PASSO 2 / STEP 2 / PASO 2

Insira a ferragem EF 000033 nas peças 03, 04, 05 e 06.
Insert the hardware EF 000033 into pieces 03, 04, 05 and 06.
Añade el herraje EF 000033 en las piezas 03, 04, 05 y 06.

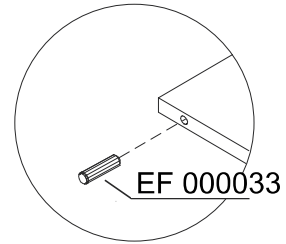
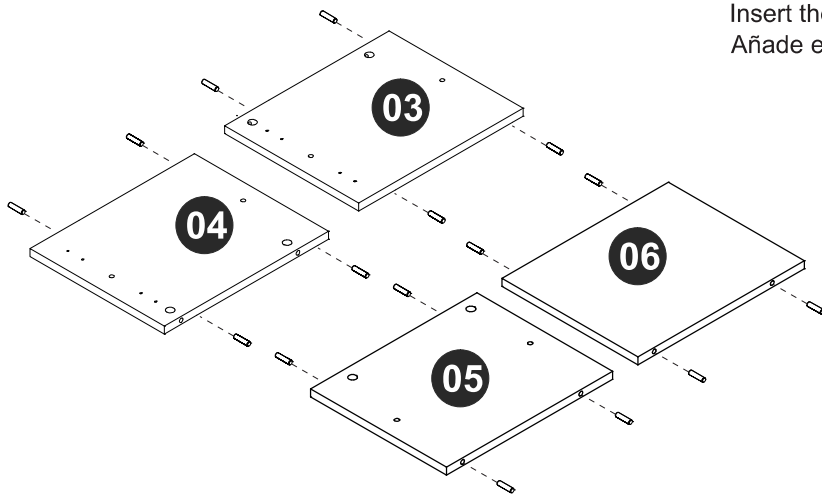

PASSO 3 / STEP 3 / PASO 3

Utilize a cola (EF 000008) antes de inserir a ferragem EF 000033 nas peças 07.
Use the glue (EF 000008) before connecting hardware EF 000033 into pieces 07.
Utilice el pegamento (EF 000008) antes de añadir el herraje EF 000033 en las piezas 07.

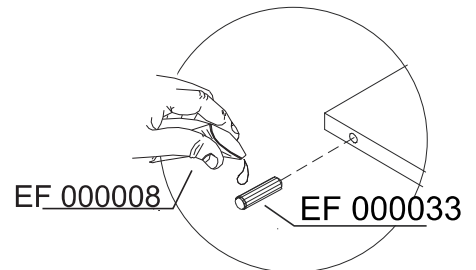
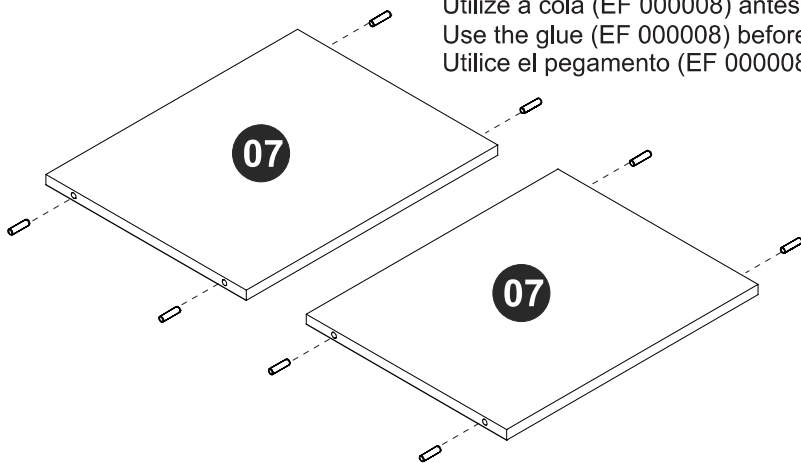

PASSO 4 / STEP 4 / PASO 4

Fixe a ferragem EF 000811 nas peças 08 e 09 utilizando a ferragem EF 000106 .
Attach hardware EF 000811 on pieces 08 and 09 using hardware EF 000106 .
Fije el herraje EF 000811 en las piezas 08 y 09 utilizando el herraje EF 000106 .

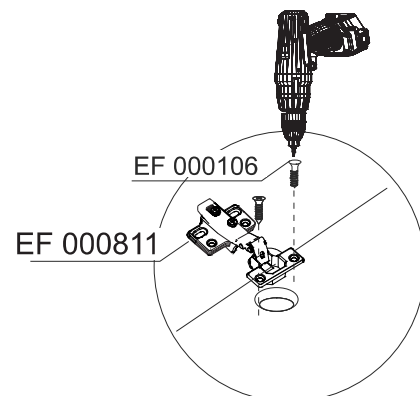
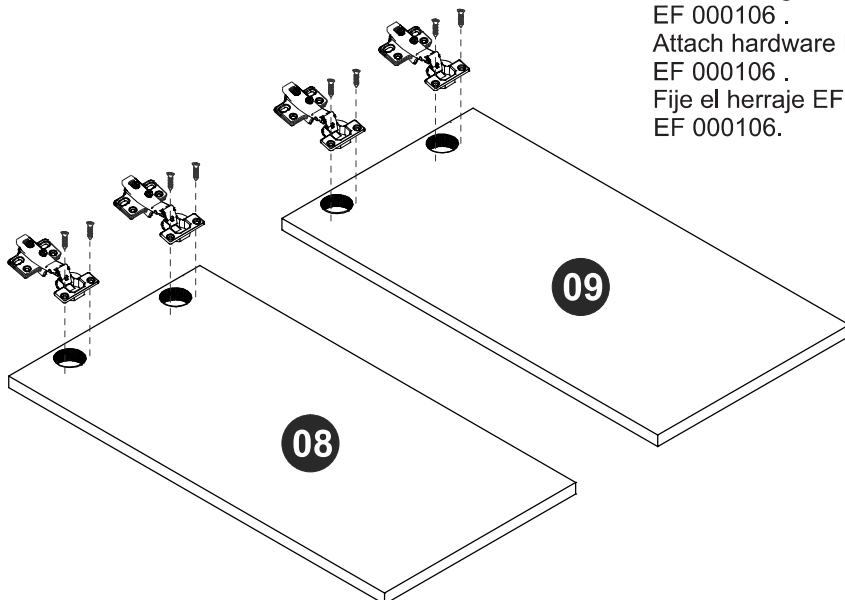

PASSO 5 / STEP 5 / PASO 5

Utilize a cola antes de conectar as peças 04, 06 e 07 e as peças 03, 05 e 07.
Use the glue before connecting pieces 04, 06 and 07 and pieces 03, 05 and 07.
Utilice el pegamento antes de juntar las piezas 04, 06 y 07 y las piezas 03, 05 y 07.

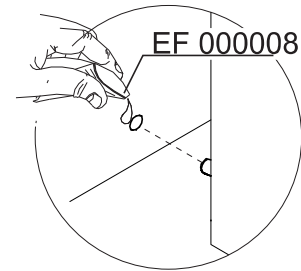
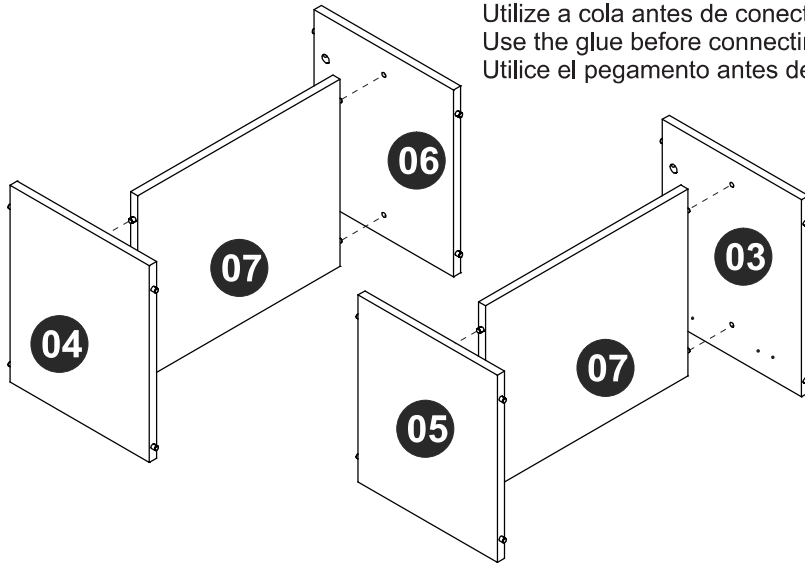

PASSO 6 / STEP 6 / PASO 6

Conecte a peça 02 à parte montada no passo anterior, insira a ferragem EF 000216 e gire para apertar.
Connect piece 02 to the part assembled in the previous step, insert hardware EF 000216 and turn to tighten.
Junte las pieza 02 a la parte armada en el paso anterior, añade el herraje EF 000216 y gire para apretar.

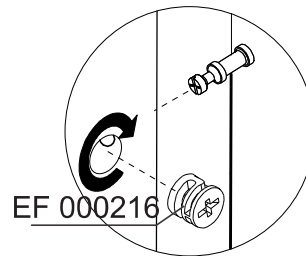
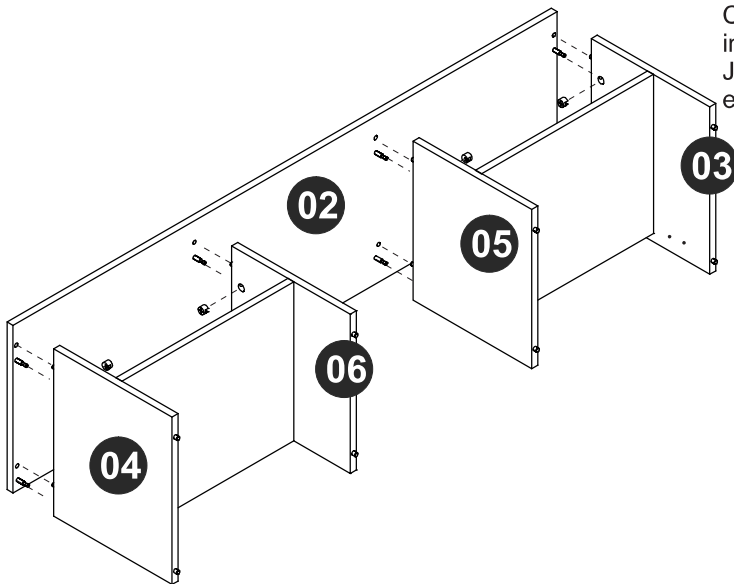

PASSO 7 / STEP 7 / PASO 7

Fixe os pés (peças 11) na peça 01 usando a ferragem EF 000107.
Fix the feet (pieces 11) at piece 01 using hardware EF 000107.
Fije los pies (piezas 11) en la pieza 01 utilizando el herraje EF000107.

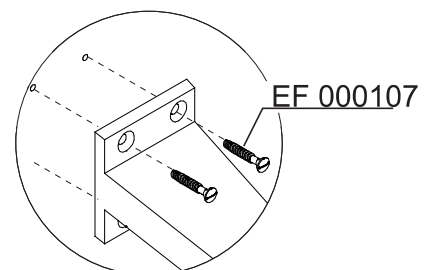
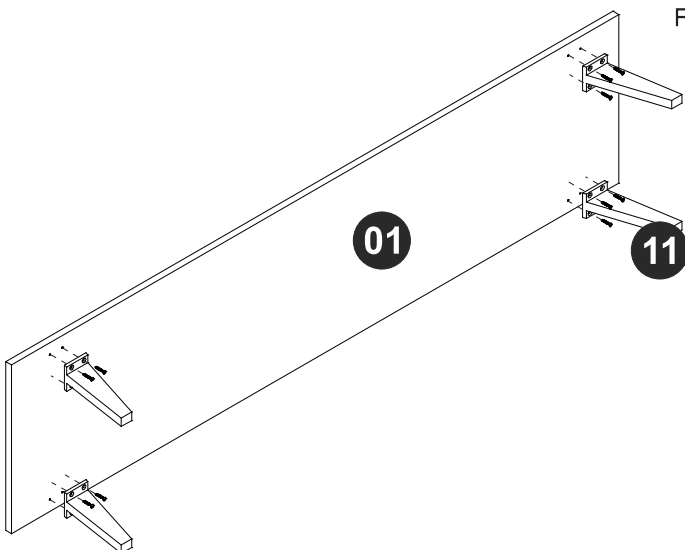

PASSO 8 / STEP 8 / PASO 8

Conecte a peça 01 utilizando a ferragem EF 000132.
Connect piece 01 using hardware EF 000132.
Junte la pieza 01 utilizando el herraje EF 000132.

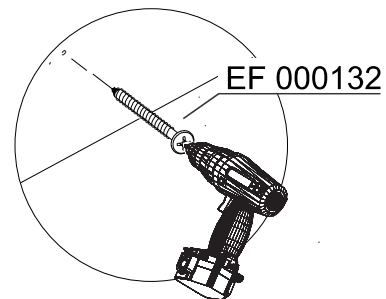
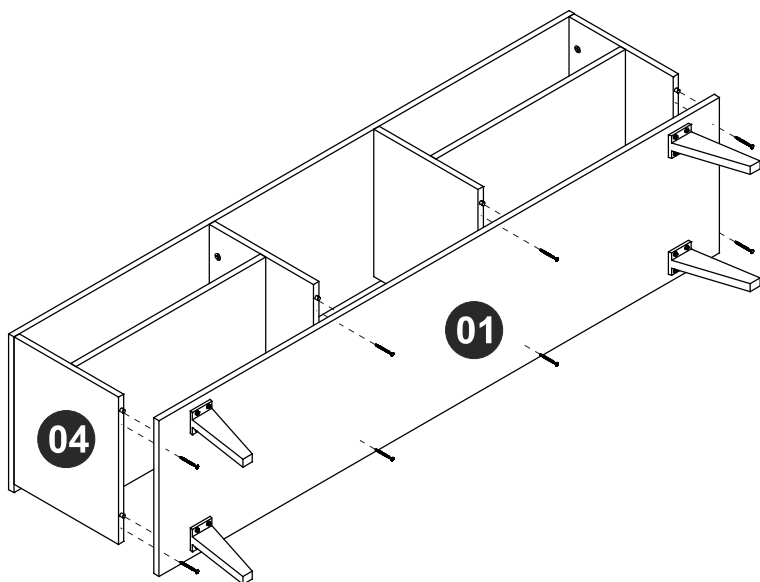

PASSO 9 / STEP 9 / PASO 9

Fixe a peça 10 ao móvel utilizando a ferragem EF 000168.
Fix piece 10 at the furniture using hardware EF 000168.
Fije la pieza 10 al mueble utilizando el herraje EF 000168.

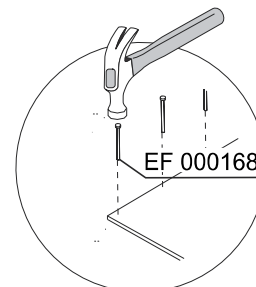
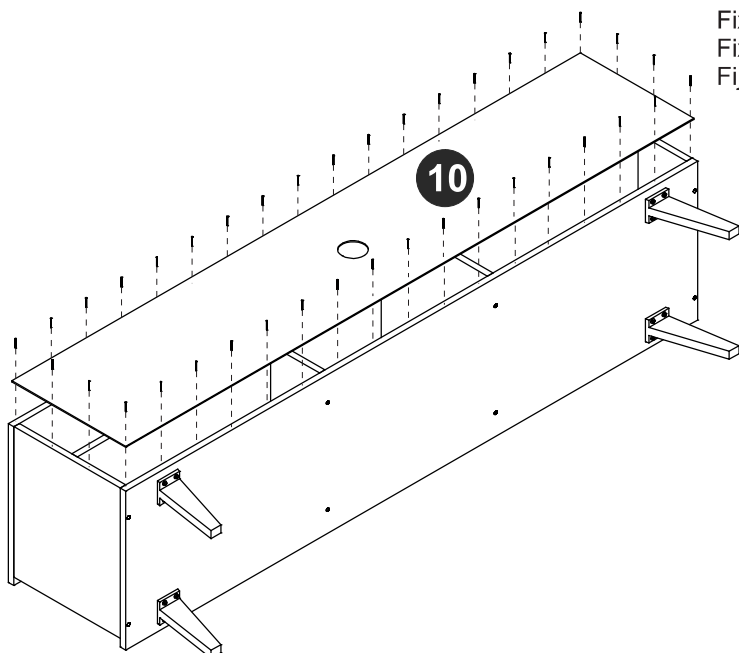

PASSO 10 / STEP 10 / PASO 10

Fixe as peças 08 e 09 ao móvel montado utilizando a ferragem EF 000106.
Attach pieces 08 and 09 at the assembled furniture using hardware EF 000106.
Fije las piezas 08 y 09 al mueble armado utilizando el herraje EF 000106.

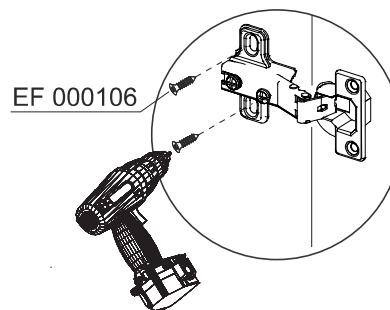
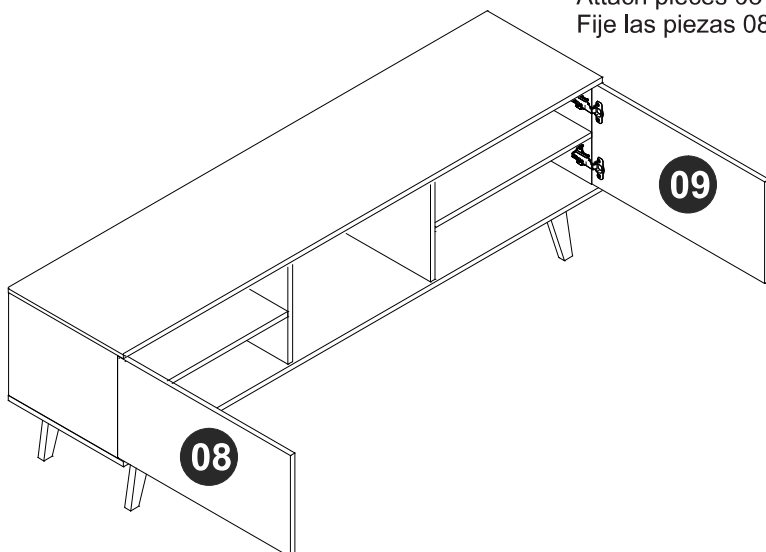

PASSO 11 / STEP 11 / PASO 11

Use o giz para dar o acabamento final ao produto. Use os tapa furos para cobrir os parafusos aparentes.
Use the chalk to give the final finish on the product. Use stickers to cover apparent screws.

Utilice la tiza para dar el acabado final al producto. Utilice los tapa huecos para cubrir los tornillos aparentes.

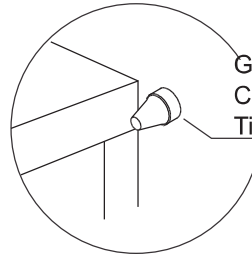
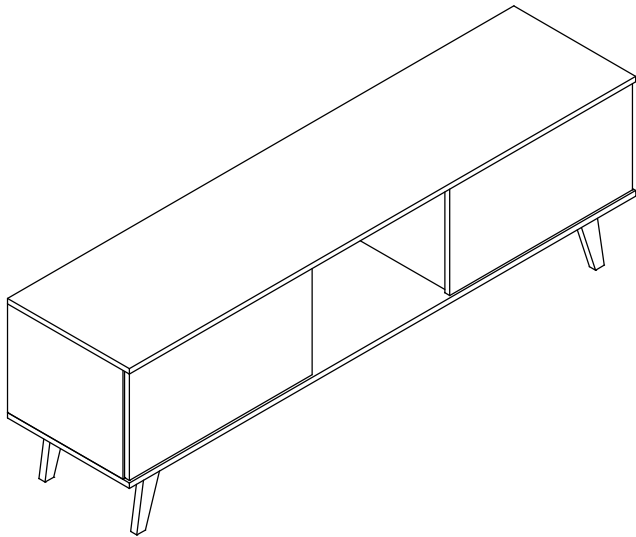

Giz
Chalk
Tiza

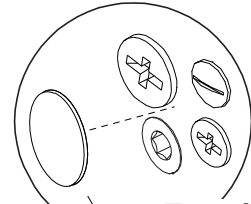

Tapa furos
Sticker
Tapa huecos

